

KOBELT

PUSH-PULL CONTROLS
HYDRAULIC STEERING & ACCESSORIES
ELECTRONIC CONTROLS
PNEUMATIC CONTROLS
DISC BRAKES

FOR THE LATEST INFORMATION
PLEASE VISIT WWW.KOBELT.COM



EDITION
2008-2009

CONTROL YOUR SHIP WITH COMPLETE SYSTEMS AND COMPONENTS FROM KOBELT MANUFACTURING

- 1 Steering components up to 320 tonmeter for hydraulic steering of single and multi-rudder vessels
- 2 In the aftdeck control station, complete control over all propulsion and deck machinery.
- 3 Hydraulic cylinders and control devices for lowering and raising masts, davits for lifeboats, loading ramps etc.
- 4 Weatherproof controls for outside stations to control propulsion and deck machinery.
- 5 Control components for propulsion and deck machinery, plus electronic alarm systems and electronic telegraphs.
- 6 Control for all deck machinery such as anchor and towing winches.
- 7 Controls for bow thrusters.
- 8 Control components for any propulsion package, fixed pitch CP propellers, load share and load control.
- 9 Propeller shaft disk brakes, from small engines up to 50,000 HP.
- 10 Control components to control stern thrusters.



KOBELT CONTROLS

WHY ARE KOBELT CONTROLS THE BEST?

All components are made from die-cast bronze with stainless steel hardware. 1-11 are indicated on the product image at right.

1. Solid bronze frame for watertight installation
2. Stainless steel shaft supported in two bearings
3. Large pins and bearings for long life
4. Roller type detent
5. Adjustable nylon throttle friction
6. Neutral safety switch
7. In-line push or pull on cable end
8. Removable solid bronze dome
9. Reverse motion hook-up for clutch and throttle
10. Several connection points for cable to suit engine and gear
11. Over-riding throttle (pull out)
12. Mounting screws under the dome
13. Easy installation and maintenance
14. Throttle movement proportional to handle travel
15. All parts interchangeable
16. Five year warranty with sales and service around the world

Kobelt push-pull controls are manufactured under one or more of the following Patent Numbers, further patents pending.

Canadian Patent Numbers	U.S. Patent Numbers
1153673	4280371
1158136	4326612
1206842	4453428
1185878	4512451
1176139	4470492
1166097	4478109
1202292	4592526
	4730507

For more information contact:
Dealer

No other control can offer all the above and match the Kobelt Price.
Brochures are available on many of our other products or visit our
website at www.Kobelt.com

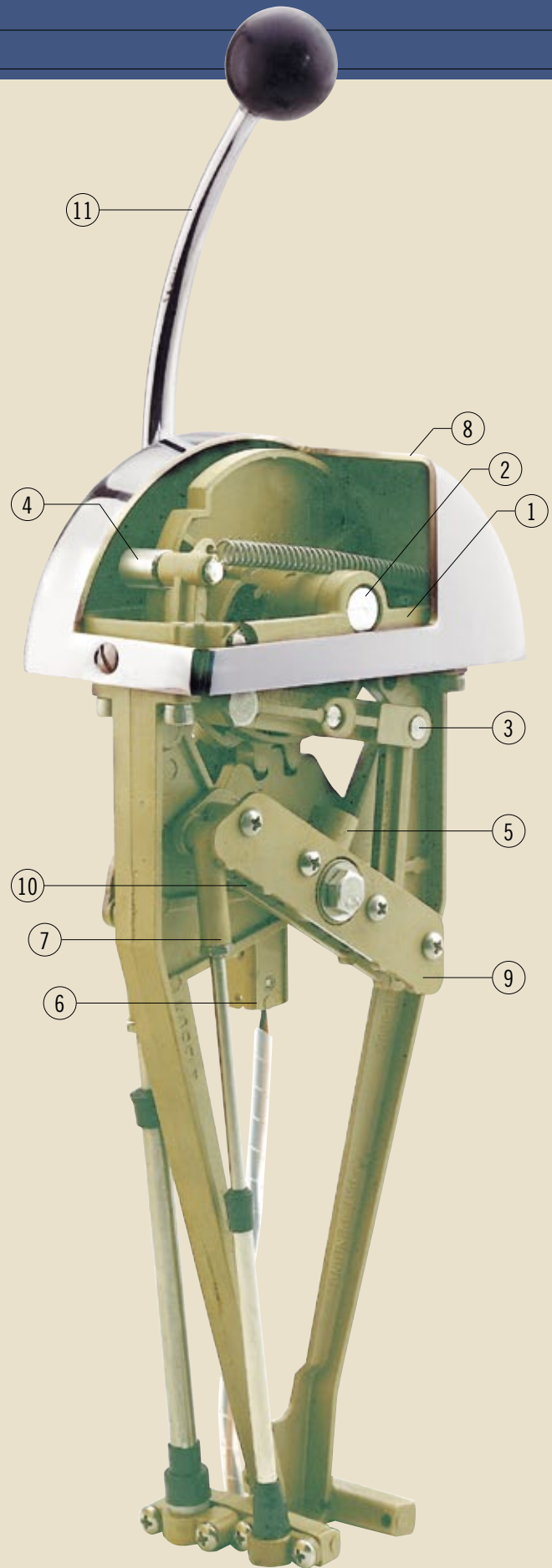

This guide will take you from general questions to a specific Kobelt product to meet your needs. If you are replacing another manufacturer's control, use the replacement guide on the bottom of page 5. After selecting a control, you will probably need some accessories to connect the control head to cables, or the engine. Please refer to the accessories section on page 24.

NUMBER OF STATIONS

If you want to be in control at 1 or 2 locations ("stations"), then push-pull controls will work for you. If you have 3 or more stations, push-pull might work but generally people should use Electronic, or Pneumatic or Wire-Over-Pulley controls.

We recommend Electronic controls for most three station systems.



SIZE OF VESSEL

Push-Pull is a mechanically connected system. It uses cables to connect control heads to the clutch and throttle. If the total length of cable is less than 50 feet (15 meters), push-pull can work for you. If the cables need to have many bends, or the connection length is more than 50 feet, Electronic controls would be the best choice. That depends largely on how easy it is to operate the clutch and engine interfaces. Some are very stiff and need a powered actuator.

There are vessels with 80 feet of push-pull cable that work well. If you need more than 50 feet for a push-pull system, please contact us.

We would need to evaluate your requirements. Please tell us:

- the number of cable bends,
- the cable length, and
- the number of stations.

We will give you our recommendation for a good working control system.

Tech Tip: For 2 station systems, the cable length is considered to be the total length for both stations. For example, a 20 foot cable to one station, plus a 30 foot run for the other station, is a total of 50 feet. If you are using more than 30 feet of cable, you should use the 40 series cable. It will last longer and run smoother.

WHAT IS YOUR PREFERENCE?

A) SEPARATE HANDLES: ONE FOR CLUTCH AND ONE FOR THROTTLE

B) COMBINED CLUTCH AND THROTTLE: "SINGLE LEVER"

Some people prefer to separate the clutch and throttle into separate handles.

Others prefer combining the clutch and throttle in one handle. This is called "Single Lever" control: From the neutral position, push forward to engage the clutch and then push further for forward speed. Reverse is achieved by pulling back from the middle position to engage the clutch. Pulling back further would increase the reverse speed.

43 Series Cable



47 Series Cable



A) SEPARATE HANDLES: ONE FOR CLUTCH AND ONE FOR THROTTLE

EVERY CONTROL HAS VERY FLEXIBLE ORDERING OPTIONS.

ONE ENGINE

Order one **2009-AK**. The 2009 is our most popular push-pull control head. The control shown on the left is the “AK” version. The “A” means that the control comes with one long handle for clutch, and one short handle for throttle. The clutch handle has an adjustable neutral detent. A detent gives you a “click” so you know where neutral is (without looking at the control). The throttle handle has an adjustable friction so you can get the right feel for your control. “K” is for a chrome finish. There are many other options available to you. Options are explained on the individual product pages.

TWO ENGINES

Order two **2009-AK** or if you want both clutch handles on the same control head, order:

- One 2009-BK Controls Two Clutches, and
- One 2009-FK Controls Two Throttles.

The “BK” has two long handles, each with an adjustable neutral detent.

The “FK” has two short handles with adjustable frictions.

If you have two stations, simply double the quantity that you need.

The following controls can be substituted for the 2009:

- 2011 This product is a heavy duty version of the 2009 and is better for longer cable runs.
- 2012 This product is the toughest push-pull control available and also allows for 4” stroke.
- 2014 Illuminated control head (for those quiet nights at sea).
- 2015 A different style and fewer options. e.g. No Interlock.

The ordering options for these substitutes are similar to the 2009.

e.g. 2011-AK is for one long handle with a neutral detent (Clutch), and one short handle with friction (Throttle). The individual product descriptions will give you all the details you might need.

THREE OR MORE ENGINES

We offer a stackable control head that is commonly used by the premium race boats. This is our 2016 control head. This model shows two throttles and two clutches. We can make any combination of handles to meet your needs.

If you have two stations, simply order two identical control heads.



2009-AK



2009-BK



2009-FK



2014



2015



2016

B) COMBINED CLUTCH AND THROTTLE: "SINGLE LEVER"

ONE ENGINE

One Station

Order one **2046-KUZ**. The 2046 is our most popular single-lever control. It has various appearance options. Some of the options are:

- Curved or straight handles.
- Chrome, black, or polished bronze

Alternatively, you can choose one of these other controls:

- 2050 Very Heavy Duty control head, and has a separate small lever for throttle (engine warm up).
- 2042 Side mount control (mounts on side of panel, not top).
- 2043 Side mount control for heavy duty situations like controlling a small water jet's bucket.

Two Stations

This is the best two station system on the market. The unique design is very easy to operate. Order:

- One 2091-KYZ Primary control head, and
- One 2093-KYZ Secondary control head.

"KYZ" means chrome, straight handles, and a metal label on the dome.

The 2091 can be substituted with either of these controls:

- 2095 Illuminated primary control.
- 2081 Has a separate small lever for trolling.
- 2085 Illuminated version of 2081.
- 2044-91 Side mount primary control.

The 2093 can be substituted with:

- 2097 Illuminated secondary control.

TWO ENGINES

One Station

The **2047-KUZ** is a twin engine version of the 2046 control head.

"KUZ" means chrome, curved handles and a metal label on the dome.

Alternatively, two single engine controls can be used, such as the 2046.



2046-KUZ



2091 KYZ

2093 KYZ



2047-KUZ

B) COMBINED CLUTCH AND THROTTLE: "SINGLE LEVER"

Two Stations

This is very similar to the 2091 and 2093 system. The 2092 is simply a twin engine primary control head. To have a twin engine, two station, single lever control system, order:

- One 2092-KYZ Primary control for twin engine, and
- One 2094-KYZ Secondary control.

The 2092 can be substituted with:

- 2096 Illuminated primary control.

The 2094 can be substituted with:

- 2098 Illuminated secondary control.

THREE OR MORE ENGINES

For three or more engines, single station, we offer the 2020 Control head. Information for this new product is on page 12 of this brochure.

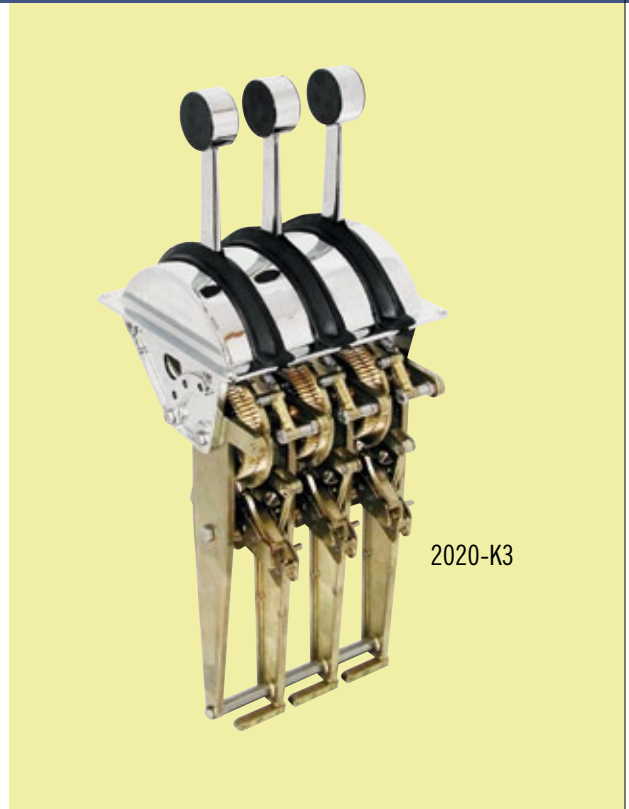

2020-K3

NEED ACCESSORIES? SEE PAGE 24

You will need cables and connection kits. Connection kits attach the cable to the control head. There are 2 sizes: 33 series cable, and 43 series cable. We recommend 43 series for longer life and easier operation. You probably need connection kits and rod ball ends for connecting the cables to your engine and clutch.

For the 2091, 2092, 2093, 2094 controls, you will need 47 series cable to interconnect the primary and secondary controls. These are special low-friction pull-pull cables. Kobelt carries a large stock of these cables, and they can also be acquired from Felsted. The kits for the 47 series cables are included with the control head.

REPLACEMENT CONTROLS

If you have one of these controls, we have a drop-in replacement for you.



2015-AK
replaces Morse™ Twin S



2046-KUZ
replaces Morse™ MT



2047-KUZ
replaces Morse™ MT-2



2022-K
replaces Morse™ SF

KOBELT CONTROLS

STANDARD FEATURES

Our control heads are available in a polished brass finish, polished chrome and black epoxy. When ordering please state finish required. The controls are equipped with adjustable friction or detent. A choice of various handle lengths is available; when ordering please specify. Neutral safety switches are available for all models. Stroke limitation screws are also provided on one and two handle control heads. All domes are removable for easy installation and adjustment. Kobelt Manufacturing produces a vast number of different control components and it is, therefore, very easy for us to produce **custom-made** control heads, all simply assembled from standard components in various configurations.

When ordering control heads, specify model number and letter code designation.

Ordering Information:

Letter code designations

- A – One short handle with friction and one long handle with detent.
- AA – One short handle with friction and one long handle with friction.
- B – Two long handles with detent.
- C – Two long handles with friction.
- D – Two long handles with one detent and one friction.
- E – Two short handles with detent.
- F – Two short handles with friction.
- G – Two short handles with one detent and one friction.
- *H – With one neutral safety switch.
- *J – With two neutral safety switches.
- K – With chrome finish cover and handle.
- L – With polished brass finish cover and handle.
- M – With black epoxy finish cover and chrome handle.
- MM – With black epoxy finish cover and handle.
- N – One long handle with detent.
- NN – One long handle with friction and detent.
- O – One long handle with friction.
- P – One short handle with detent.
- PP – One short handle with friction and detent.
- R – One short handle with friction.
- S – Right hand model.
- T – Left hand model.
- U – Curved handle.
- V – T-bar handle with coloured plastic grips.
- W – Removable sailboat handle.
- Y – T-bar handle (standard).
- Z – With riveted metal labels.

When ordering Kobelt adapter kits for control heads, specify the control head number followed by -0901 for 30 series adapter kit and -0902 for 40 series adapter kit.

For neutral safety switch please specify control head number followed by -0903.

*Neutral safety switch is normally installed on the detented handle.



PUSH-PULL CONTROLS

BASIC INFORMATION ON PUSH-PULL CONTROLS

The mechanical push-pull control is a very simple and easily installed system for smaller boats. The equipment controlled by a system of this type must be relatively easy to operate. Kobelt provides a variety of hydraulic-actuated power assist units for use on clutch and throttle applications requiring additional mechanical force (Part No. 4602, 4605).

We generally do not recommend the installation of more than two stations with push-pull cables. If the cable runs are relatively short and straight, it is possible to make a three-station system work. For a multi-station, single lever control system, a combination of wire-over-pulley and push-pull with our model 2051 master control works extremely well (for up to four stations).

The Kobelt single lever control heads 2042, 2043, 2044, 2046, 2047, 2048, 2050 and 2054 are designed to work as a one-station control only.

The 2080 series and the 2090 series are designed for 2 stations. These controls provide single lever control for clutch and throttle from two stations and are available in single and twin engine configurations. This system (Patent No. CDN. 1206642, 1158136; US 4512451, 4280371, Further Patent Pending) has proven to be a tremendous success due to its exceptional performance and durability.

We also produce complete systems for wire-over-pulley, electronic and pneumatic controls, as well as propeller shaft brakes and electrical control components.

Kobelt products have a global reputation for durability and performance, and are constantly being improved upon. Most of our products are patented, evidence of the Kobelt commitment to better design and efficiency.

We are unique in the marketplace as we are the only manufacturer providing a non-corrosive product for the marine environment. Using the best materials for construction and skillful engineering has enabled us to offer our customers a five-year warranty.

Kobelt controls are sold through distributors worldwide. For more information on Kobelt and our complete product lines, contact your nearest distributor.

GENERAL INFORMATION

Kobelt Manufacturing does not produce a push-pull cable. There are many push-pull cable manufacturers in the world working with the same dimensional specifications, therefore, the cables are all interchangeable. There is, however, a tremendous variation in the structural quality and design. We recommend the use of low friction cables with flexible cores, such as those manufactured by Felsted®.

TECHNICAL SPECIFICATIONS

Kobelt control heads are designed to be used with either 30 or 40 series cable so please specify when ordering. Our heads and adapter kits are also designed to accept the clamp type cable ends. The minimum bending radius recommended by us is 8" (200mm), the maximum load in push and pull mode on the 30 series cable should not exceed 50 lbs. (22kg) and the maximum load on a 40 series cable should not be greater than 100 lbs. (45kg).

INSTALLATION INSTRUCTIONS

A push-pull control system is dependent largely upon the quality of the cable and the layout of the installation. An excessive number of bends, especially small radius bends, will make a control system of this nature stiff and difficult to handle. It must be installed to eliminate as many bends as possible and also provide generous radii, especially on multi-station installations. On long and multi-station cable runs we can provide ball bearing cables to reduce the friction and lost motion from conventional cables. These cables are very expensive and Kobelt electronics or air controls, in many cases, will do the job just as efficiently for less. Kobelt only recommends the use of ball bearing cables when there is absolutely no way of installing compressed air, electronics or a wire-over-pulley system.

POWER ASSIST UNITS

Kobelt also provides a variety of hydraulic power assist cylinders to aid the push-pull cable in controlling clutches and throttles. For further details regarding servo cylinders and product numbers 4602, 4605 and 4607, please refer to page 27 or consult our factory or your nearest distributor.

2002 TWIN HANDLE BRASS CONTROL HEAD 3" STROKE



Our Model 2002 is designed for small workboats and pleasure crafts for single or two station control of engine speed and gear box direction. Its rugged design, simplicity of construction and quality of material (bronze and stainless steel hardware) will give years of trouble-free service with a minimum investment. The throttle must be at idle before the gear control lever can be moved to any position. This feature will protect the gear box since the engine must be at idle for clutch shifting.

Letter code designations:

S, T

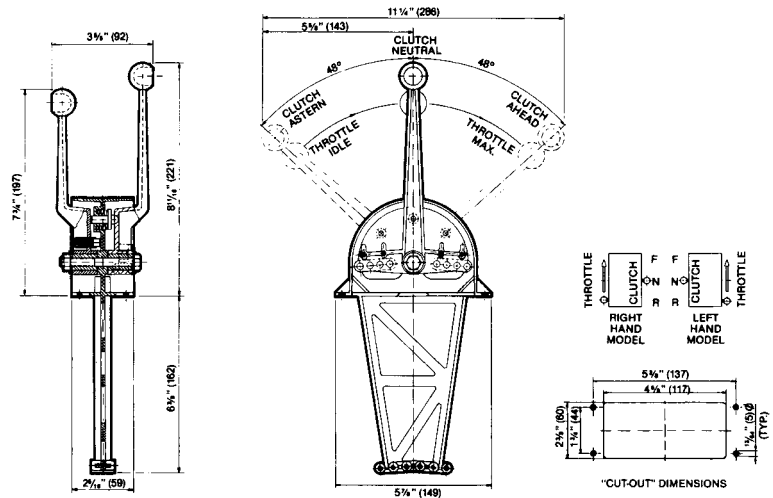

2003/2004/2006 ONE HANDLE HEAVY DUTY CONTROL HEADS



Designed and built with careful attention to quality of materials and workmanship, the rugged design incorporates practicality and contemporary styling. The all bronze and stainless steel construction of these control heads will give years of trouble-free operation.

Model 2003 and 2004 provide 3" (76mm) of cable stroke and Model 2006 provides 4" (102mm) of cable stroke. All one-handle and two-handle Kobelt control heads are equipped with frictions or detents as standard. Neutral safety switches are an optional extra; see ordering table.

Letter code designations:

H, K, L, M, N, O, P, R, V, Y, Z

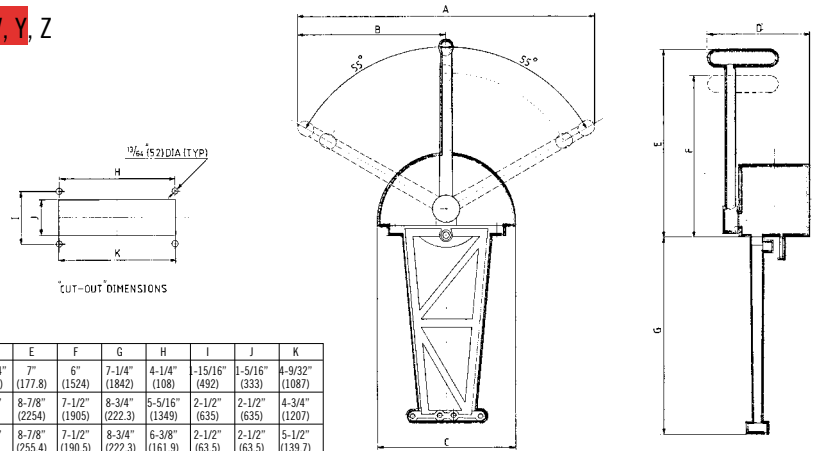

	A	B	C	D	E	F	G	H	I	J	K
MODEL 2003	11-1/16" (281)	5-17/32" (140.5)	5-1/16" (128.6)	5-13/64" (132.2)	7" (177.8)	6" (152.4)	7-1/4" (184.2)	4-1/4" (108)	-15/16" (49.2)	1-5/16" (33.3)	4-9/32" (108.7)
MODEL 2004	13-1/2" (342.9)	6-3/4" (171.5)	6-1/15" (154)	4-1/4" (108)	8-7/8" (225.4)	7-1/2" (190.5)	8-3/4" (222.3)	5-5/16" (134.9)	2-1/2" (63.5)	2-1/2" (63.5)	4-3/4" (120.7)
MODEL 2006	13-1/2" (342.9)	6-3/4" (171.5)	7-1/8" (181)	4-1/4" (108)	8-7/8" (225.4)	7-1/2" (190.5)	8-3/4" (222.3)	6-3/8" (161.9)	2-1/2" (63.5)	2-1/2" (63.5)	5-1/2" (139.7)

2009/2010 TWIN HANDLE CONTROL HEADS

These control heads are made in all bronze and stainless steel for medium duty applications. Model 2009 with 3" (76mm) of stroke can be used for one or two station installations with relatively short and straight runs. Model 2010, because of the short stroke – 2-3/8" (60mm) – is only recommended for one station control.

Letter code designations:

A, AA, B, C, D, E, F, G, H, J, K, L, M, V, Y, Z

	A	B	C	D	E	F	G
MODEL 2009	11-1/16" (281)	5-17/32" (140)	5-1/4" (133)	6-1/8" (156)	7" (178)	6" (152)	7-1/4" (184)
MODEL 2010	10-7/8" (276)	5-7/16" (138)	4-3/4" (121)	503/4" (146)	7" (178)	6" (152)	7-5/16" (186)

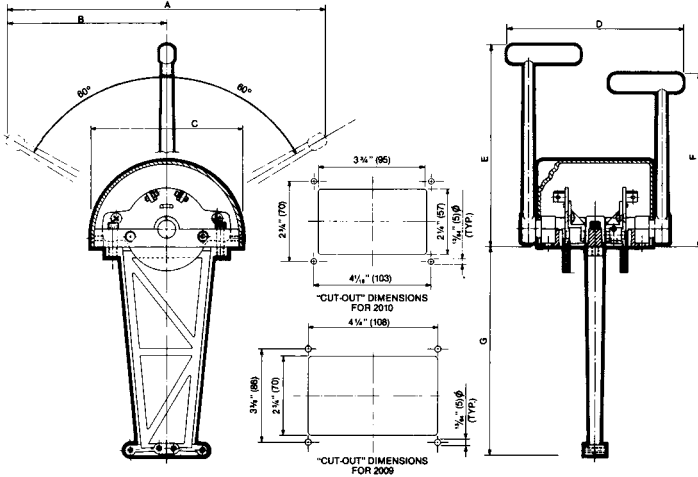

A throttle and clutch interlock (similar to our Model 2002) is available for Model 2009. Please specify when ordering: S or T.



2011/2012 TWIN HANDLE HEAVY DUTY CONTROL HEADS

These controls are designed for one or two station applications to control reasonably heavy movable clutches and throttles (not mechanical clutches). The heavy duty construction of these units will provide years of trouble-free service. Model 2011 has a maximum of 3" (76mm) of cable stroke and model 2012 has 4" (102mm). Several attachment points for the cable are provided, as well as handle travel limitation screws.

Letter code designations:

A, AA, B, C, D, E, F, G, H, J, K, L, M, V, Y, Z

	A	B	C	D	E	F	G	H
MODEL 2011	14-3/16" (360)	7-3/32" (180)	5-15/16" (151)	6-5/8" (168)	8-15/16" (227)	7-1/2" (190)	8-3/4" (222)	5-1/4" (133)
MODEL 2012	14-3/16" (360)	7-3/32" (180)	5-15/16" (151)	6-5/8" (168)	8-15/16" (227)	7-1/2" (190)	8-3/4" (222)	6-3/8" (162)

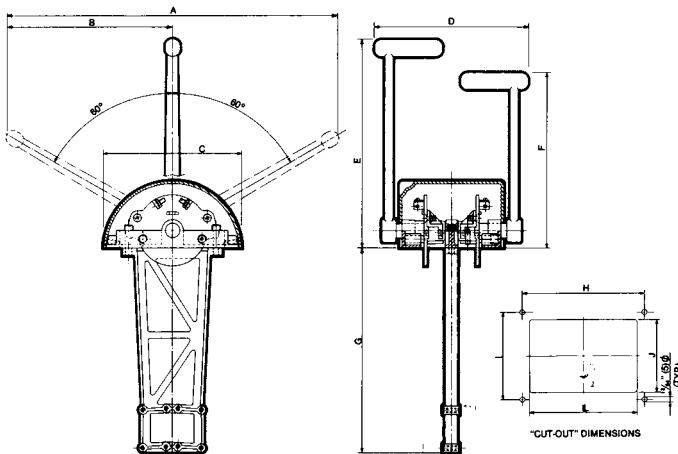

A throttle and clutch interlock (similar to our Model 2002) is available for Model 2011. Please specify when ordering: S or T.



The 2008 and 2014 are the most stylish mechanical control heads available in the world, with illuminated side scales and all bronze and stainless steel construction. The two control heads provide a maximum of 4" (102mm) of stroke. Neutral safety switches are available with these heads. Frictions and detents are standard – order to suit your application.

The 2008 is a one-handle push-pull control that can be used for either clutch or throttle applications. The 2014 can be used for either twin clutches, twin throttle, or clutch and throttle applications. Various side scales are available and must be ordered to suit your requirements. Short and long handles can also be ordered.

Letter code designations:

Model 2008 H, K, L, M, N, O, P, R

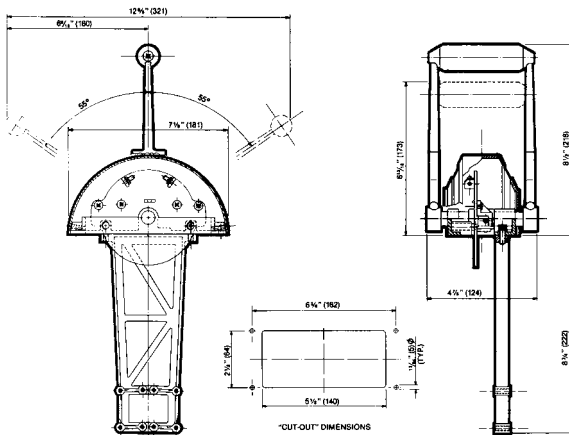

Letter code designations:

Model 2014 A, AA, B, C, D, E, F, G, H, J, K, L, M

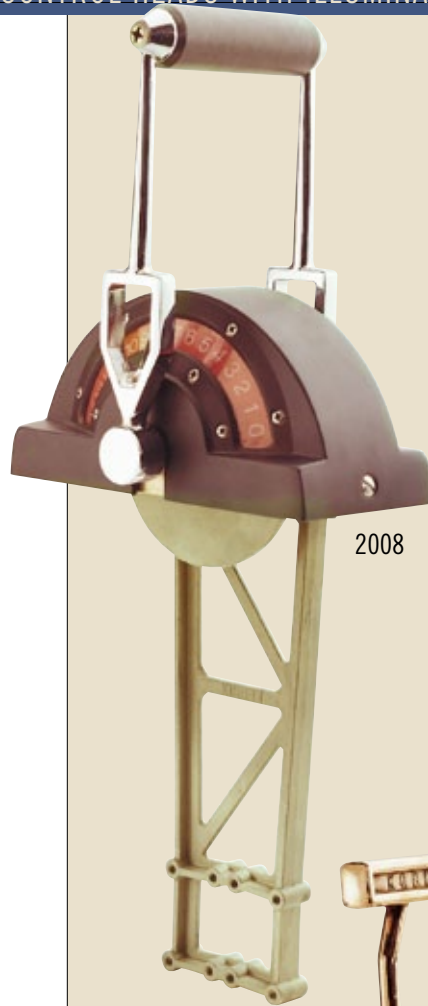
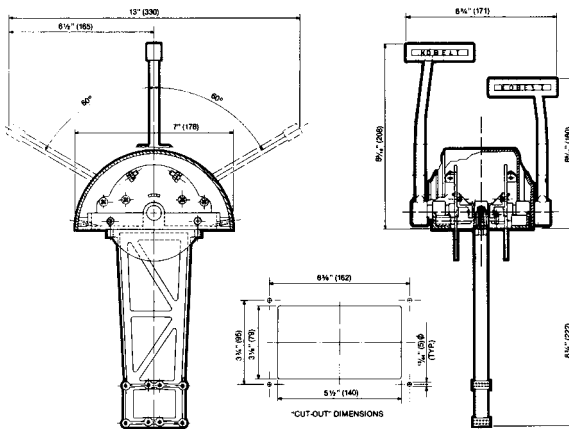

2008



2014

2015 TWO HANDLE PUSH-PULL CONTROL HEAD

This control incorporates all the features of the Kobelt standard Push Pull Control: 3" strokes, all bronze and stainless steel, and extremely heavy duty construction. The cable support bracket has been shortened to improve cable attachment access to the Control head.

Letter code designations:

A, AA, B, C, D, E, F, G, K, L, M, U, V

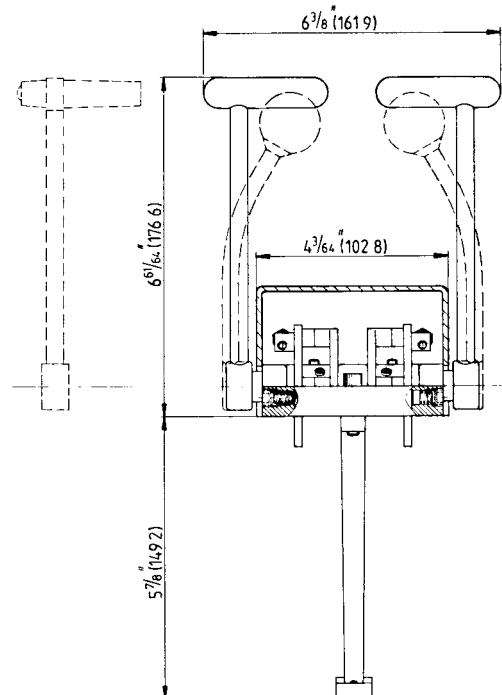
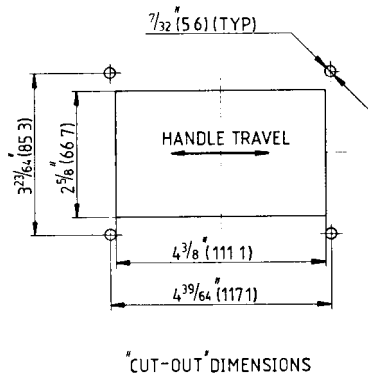
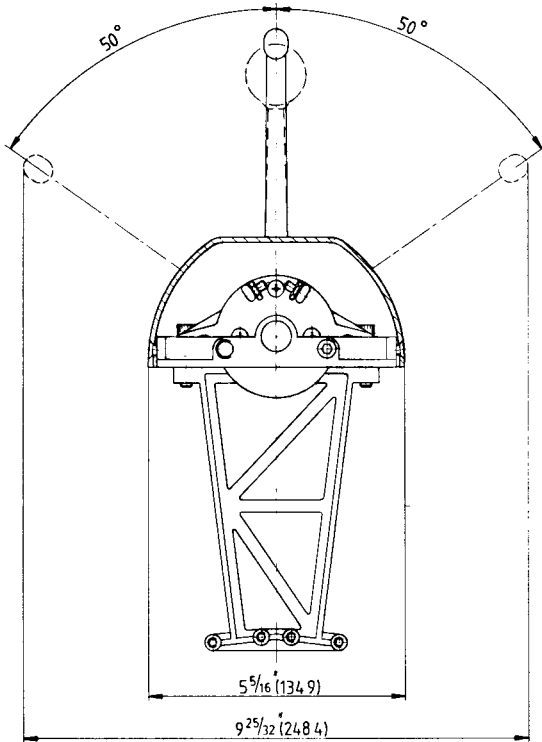

2016 STACKABLE FLUSH MOUNT CONTROLS

Hi-Performance Race Boat Control

This control is totally constructed in bronze and stainless steel. The levers can be combined to suit customer requirements and an almost unlimited variety of control functions can be accomplished.

The Model 2016 does not provide single lever control. Only ONE function can be accomplished per lever. For single lever function we offer the 2020 control head – see below for information on this new product.

Letter Code Designations:

A, A1, B, C, D, E, F, G, H, J,

K, L, M, MM, N, O, P, R

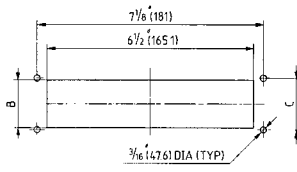

CUT-OUT DIMENSIONS

	A	B	C
1 HANDLE	2 1/4 (57.2)	1 1/2 (38.1)	1 9/16 (41.3)
2 HANDLES	3 3/16 (84.1)	2 1/16 (65.1)	2 11/16 (68.3)
3 HANDLES	4 3/8 (111.1)	3 3/8 (92.1)	3 3/4 (95.3)
4 HANDLES	5 1/16 (138.1)	4 1/16 (119.1)	4 3/16 (122.2)

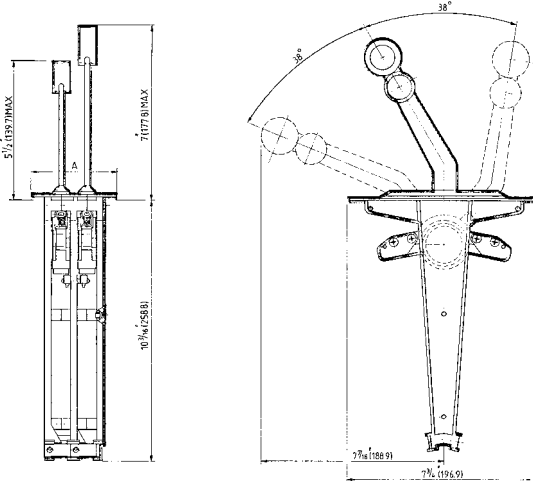

2020 SINGLE LEVER, DUAL FUNCTION MULTI-ENGINE CONTROL

The 2020 control head offers more features than any other control of this type in the world. It was designed for dual function (clutch and throttle), single lever mechanical controls.

It is constructed entirely in bronze and stainless steel with a low profile dome per our customers' requests. The mechanical output portion is on a swivel base, allowing the cables to be mounted in any of the three downward positions. Extremely robust in construction, it is intended for the most demanding applications.

This control head is available in multi-engine configuration, where the controls can be mounted side by side as shown in the product photo to the right for a three engine application and for most cable sizes. The number of controls that can be stacked together is virtually unlimited.

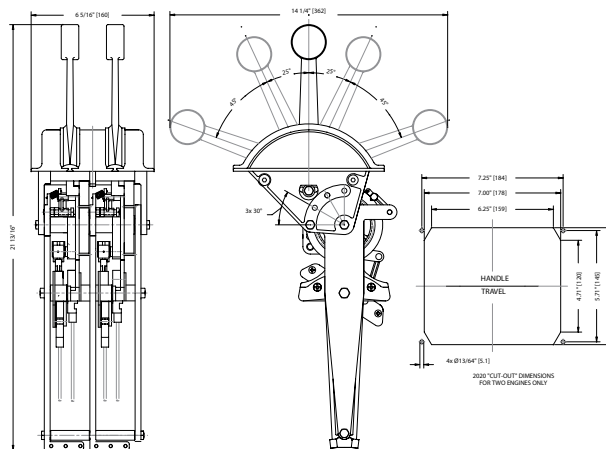

2022 TWO LEVER, LOW PROFILE MECHANICAL CONTROL HEAD

Model 2022 is a low profile control head offering the construction features of a heavy duty model without the heavy duty cost. Manufactured entirely of bronze and stainless steel, it will provide years of trouble-free service.

It is intended for single function, single handle control (i.e. separate clutch and throttle handles). Due to its efficient design it can be used as a simple “drop-in” replacement for a Morse™ SF unit.

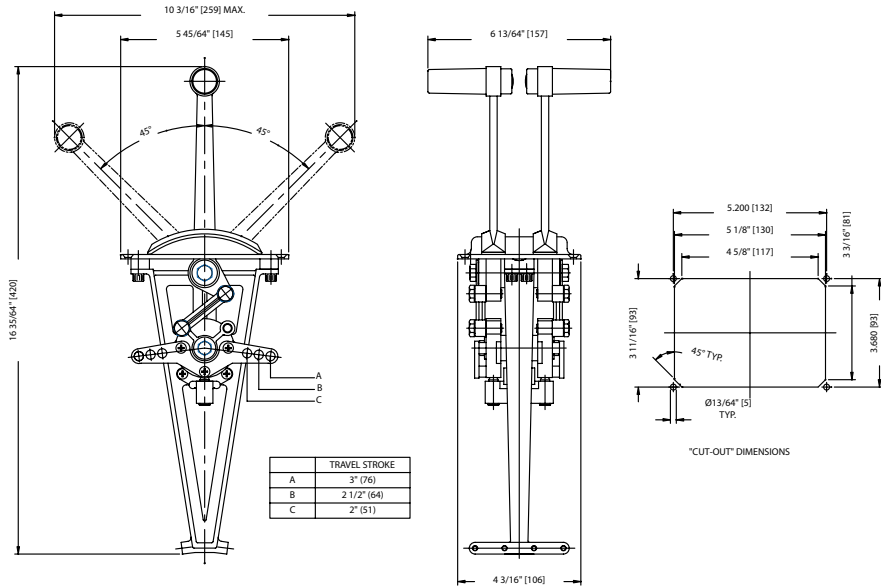

2030 SIDE-MOUNT ONE HANDLE CONTROL

The 2030 side-mounted control, provides 3-1/4" (82mm) of cable stroke and can be used for control of either clutch or throttle. Only one length of handle is available with this unit. The rugged design and large bearing will provide years of trouble-free operation. The output cable attaching flange can be rotated at 90° increments.

Letter code designations:

K, L, M, N, O

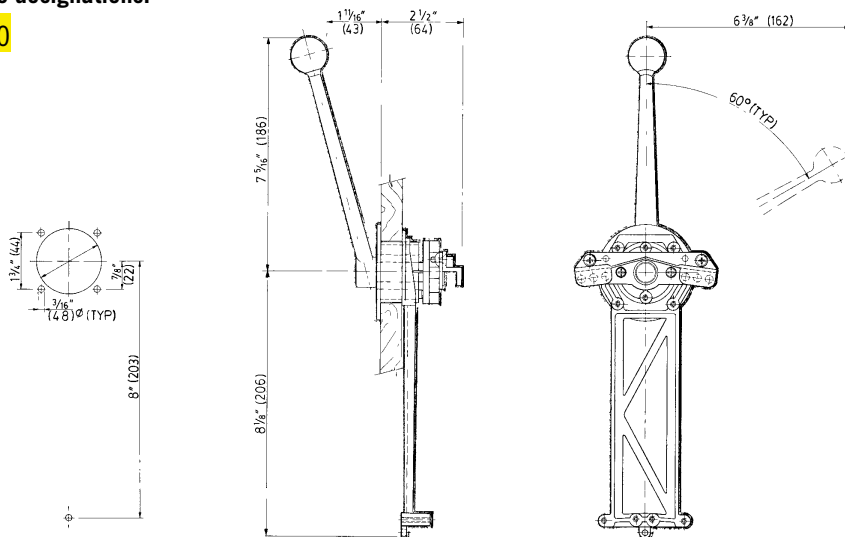

2031 TWO LEVER 2032 ONE LEVER HEAVY DUTY SIDE-MOUNT CONTROL

These sidemount controls are intended to control water jets, power take-offs, small mechanical clutches, and various other heavy duty applications where 60 series cable is employed. The long handle on both units provides from 3" to 6" of stroke. The short handle on Model 2031 will give from 1" to 3" of stroke. It is possible to use either model on a two-station (in series) application whereby two levers are provided on the backside of the control for the connection of two cables, one to the remote station and one to the item to be controlled. The all bronze and stainless steel construction will give years of trouble-free service.

Letter code designations:

Model 2031 **K, L, M**

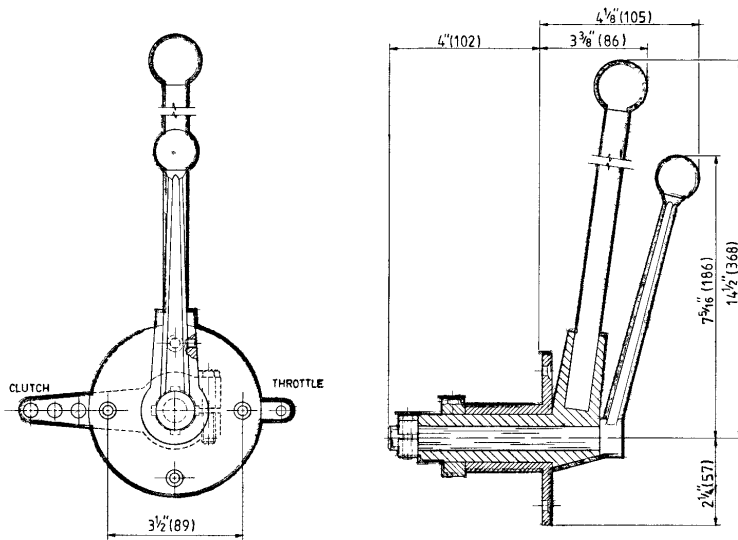

Letter code designations:

Model 2032 **J, K, L, M**

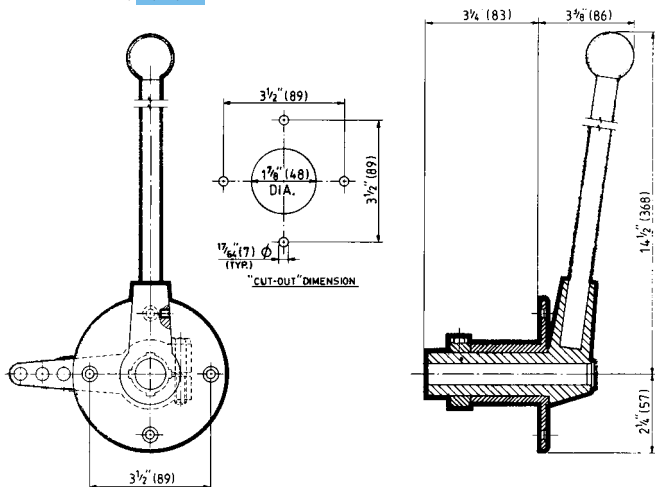

2031



2032

2042 SIDE-MOUNT, HEAVY DUTY, SINGLE LEVER CONTROL HEAD

This unit is constructed entirely in bronze and stainless steel and is intended for the discriminating boat owner who is looking for durability and performance. It incorporates all of the features that make for good boating. The control handle has a very large arc of rotation to give good feel over both clutch and throttle. A clutch override button is provided to allow acceleration of the engine without engaging the gear.

This unit is extremely compact and is available in several versions. The standard finish would be a chrome plated handle and front housing.

Letter code designations:

H, **K, L, M**

This control can be ordered (cannot be changed in the field) with the neutral position of the handle in any one of the four positions indicated. Position "1" is standard. Please add appropriate number.

Materials: Die-cast silicon bronze with stainless steel hardware.

Weight: 9 lbs. (4kg)

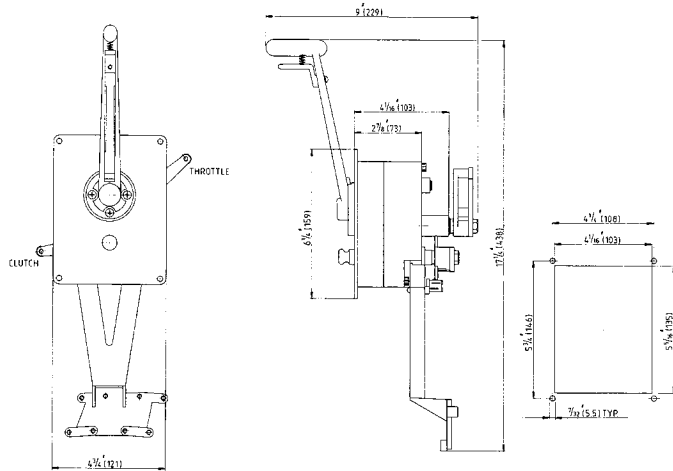

2043 SIDE-MOUNT HEAVY DUTY SINGLE LEVER CONTROL HEADS

The 2043 is a spin off from our Model 2044. The extremely heavy duty internal design of this unit allows for connection of 60 series cable for the control of small water jets and engine speed with a single lever. The control handle can be pulled out for overriding throttle. The output lever for the water jet bucket has an adjustable stroke (max 4") and can be adjusted to suit all small water jets. The throttle output lever has several attaching points for the cable with a stroke of up to 1-3/4".

Letter code designations:

H, **K, L, M**

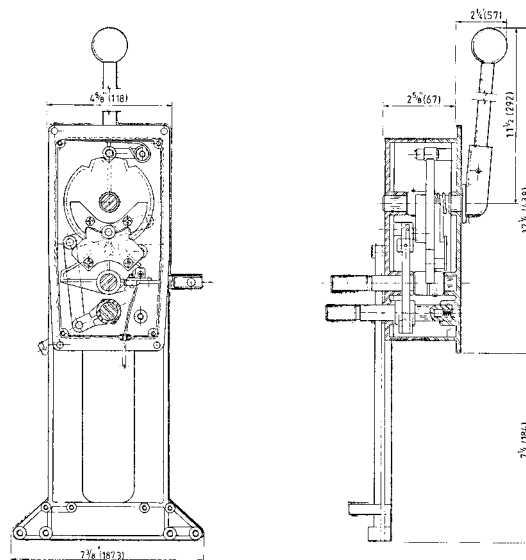

2044 SIDE-MOUNT, HEAVY DUTY, SINGLE LEVER CONTROL HEADS

Single Station Use Only

The Model 2044 is available in two different versions, (as shown) with neutral lock for powerboats and with removable sailboat handle (not shown). Also not shown is model 2045 with remote wire-over-pulley control which lends itself ideally, in this configuration, for small workboats with wire-over-pulley control leading to upper stations. This control features a pull-out handle for overriding throttle. The clutch travel is a maximum of 3" (76mm) and the throttle travel is 1-3/4" (44mm). The cable attaching bracket can be rotated at 90° increments. The control handle position can also be ordered at 90° increments.

Letter code designations:

H, K, L, M, W, X*

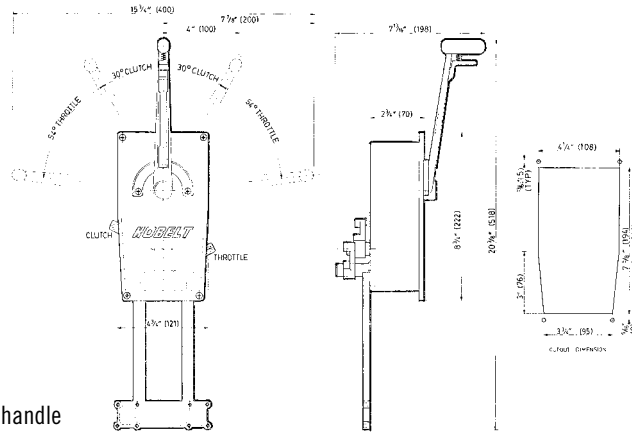

* "X" means neutral locking powerboat handle



2047 SINGLE LEVER CONTROL HEAD

This control head was recently developed by Kobelt Manufacturing, as a smaller version of the 2048, and it incorporates all of the same features. The throttle travel is 2-3/8" and the maximum clutch travel is 3".

This unit is constructed entirely of bronze and stainless steel and offers a five year warranty. It can be used in either push or pull mode for the clutch or throttle. A roller type detent is incorporated into the 2047 as well as an independent throttle override.

Letter Code Designations

J, K, L, M, U, V, Y, Z

Important: Model 2047 is designed to work as a single station unit only. Use the 2092 for two station applications.

Weight: 8.8 lbs. (4kg)

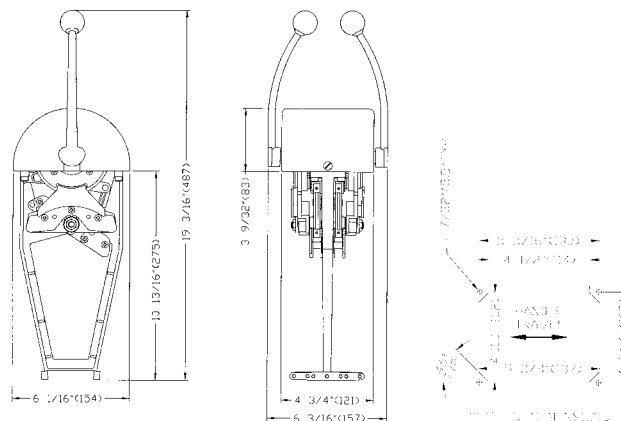

2046/2048 MEDIUM DUTY SINGLE LEVER CONTROL HEADS

Single Station Use Only

The 2046 and 2048 single lever control heads went through years of engineering and feasibility studies before we presented these products to the market. These control heads are a major evolution in single lever control because of their construction, design, size, price and options which puts them in a class by themselves; just like all other Kobelt products. They provide a pull-out handle for overriding throttle, roller detents and enumerable options. The clutch travel is maximum 3" (76mm) and throttle travel is maximum 1-5/8" (41mm). The 2048 consists of two 2046s jointed on a common frame and dome.

An optional throttle stroke extension kit is available for Models 2046 and 2048. It will extend throttle stroke to 2-5/8" and contains all necessary parts to connect either a 33 or 43 series cable.

Part #2046-0905 for 33 series cable

Part #2046-0906 for 43 series cable

Letter code designations:

Model 2046 H, K, L, M, U, V, X*, Y, Z

* "X" means short handle

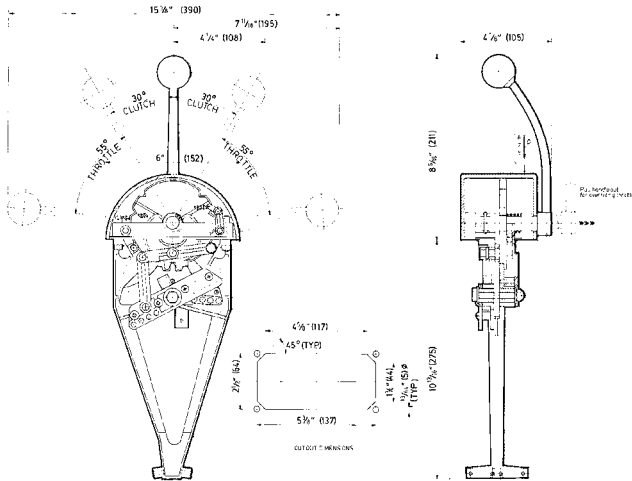

Letter code designations:

Model 2048 J, K, L, M, U, V, Y, Z

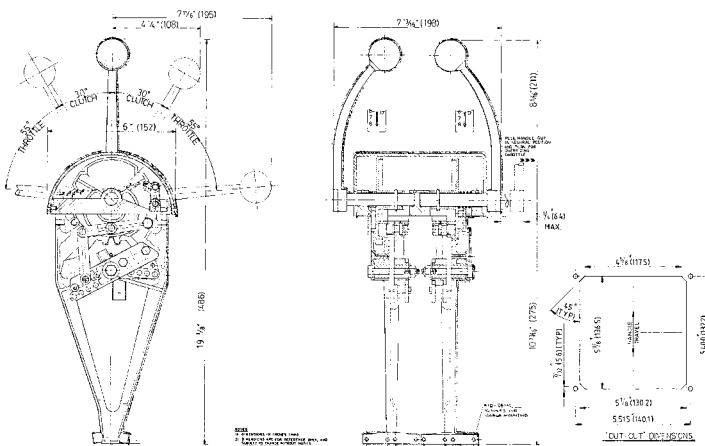

2046



2048

2050/2054 HEAVY DUTY SINGLE LEVER CONTROL HEADS

Single Station Use Only

The 2050 and 2054 are super heavy duty control heads using basically the same components except for the dome and handles. All materials are non-corrosive and are designed for years of trouble-free service. The maximum travel for the clutch is 3" (76mm) and the maximum throttle travel is 2-1/2" (64mm) for the 2050. While the clutch travel for the 2054 is the same, the throttle stroke is 2" (50mm). Various connection points provide the correct travel needed for your engine and gear. The small overriding throttle handle is only operative in the neutral gear position which prevents gear engagement at high engine speed. The 2054 (the same as 2008 and 2014) is equipped with light sockets for illumination. Dimmers can be provided to regulate the light effect to suit the owner. Many boats equipped with our 2050 series control heads have push-pull cable runs up to 75 ft. (23m) and work very satisfactorily with Felsted cables.

Letter code designations:

Model 2050 H, K, L, M, NN, PP, S, T, V, Y, Z

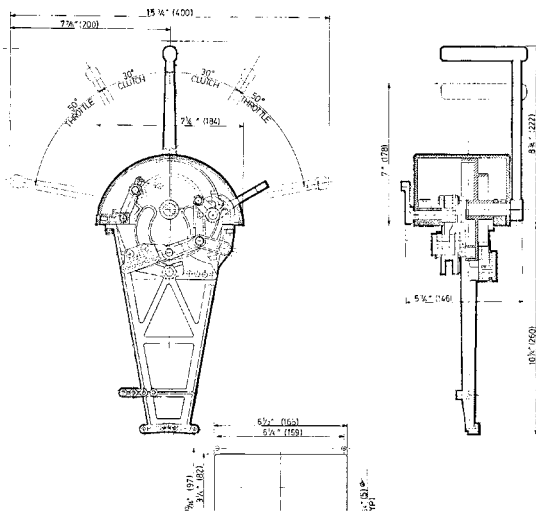

Letter code designations:

Model 2054 H, K, L, M, NN, PP

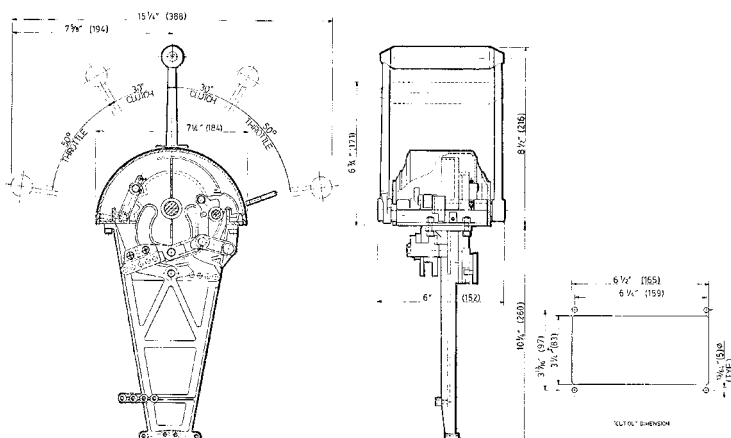

2050

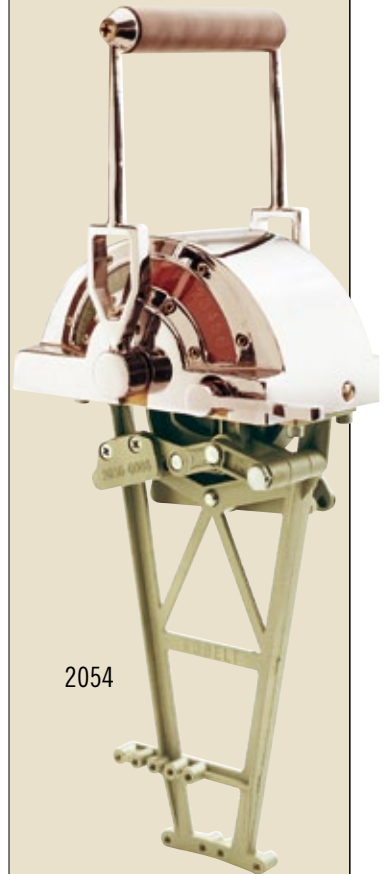

2054

2051 SINGLE LEVER CONTROL HEADS

The 2051 single lever push-pull control is basically the same as model 2050. It has, in addition, a wire-over-pulley sheave on the single lever control shaft which permits a multi station wire-over-pulley remote control. This arrangement has proven extremely satisfactory on small workboats and large pleasure crafts. Due to the ball bearing sheaves and endless cable, no friction is accumulated and the control is effortless. The bronze and stainless steel construction will provide many years of trouble-free service.

Letter code designations:

H, K, L, M, NN, PP, S, T, V, Y, Z

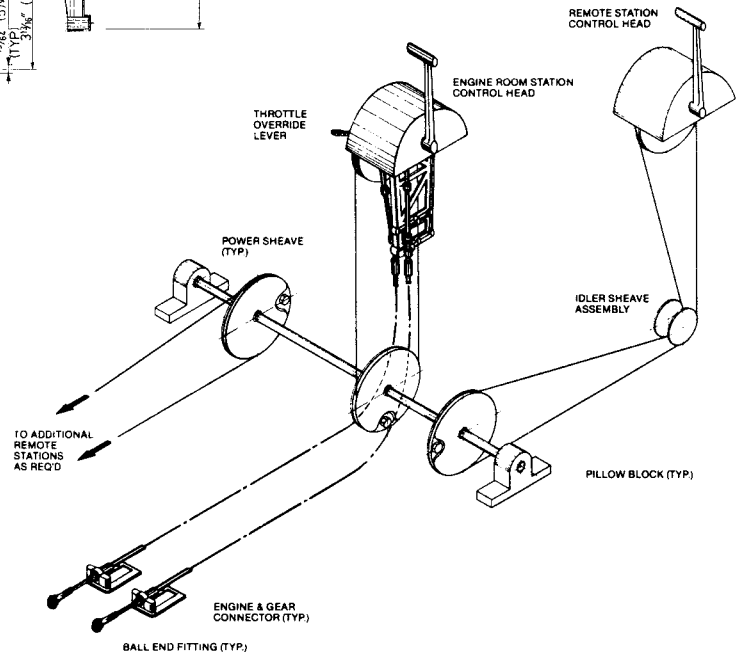
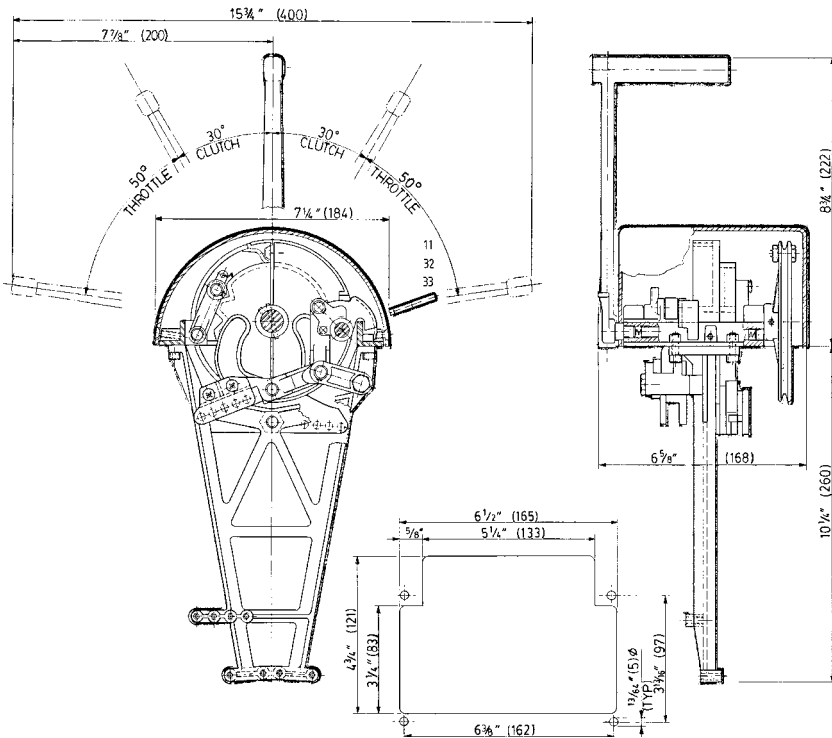

2080 SERIES

Single Lever, Single Engine Control, with Overriding and Interlocked Throttle Control Model 2081

This control operates basically on the same principle as the model 2090 with the exception that the overriding throttle is on a separate lever. The throttle lever serves the prime function of accelerating the engine while the main single lever control handle is in the neutral position. It is not possible to operate both levers at the same time since they are mechanically interlocked.

Single Lever, Single Engine Control, with Separate Trolling Valve Lever Model 2085

This control is ideally suited for one or two station applications that require trolling valve control. An interlock incorporated in this unit will only allow for trolling valve control at low engine R.P.M. The second station can be equipped with or without trolling valve control.

Remote Control with either overriding Throttle or Trolling Valve Control Model 2083

The purpose of this unit is to serve as a remote station with either Model 2081 or 2085. The secondary lever is interconnected with the overriding throttle on Model 2081 or the trolling valve control lever on Model 2085. The main single lever control is connected to the remote unit with pull-pull cables (47 series.) For a second station throttle and clutch only use Model 2093.

Letter code designations:

H, I, K, L, M, S, T, U, V, Y, Z



2081

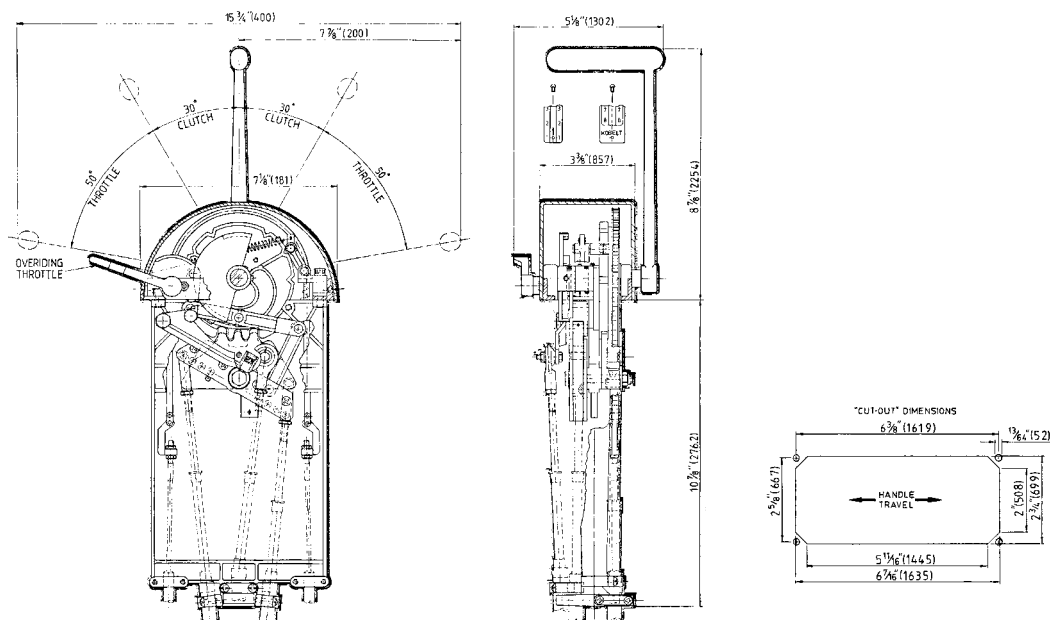

2090 SERIES – TWO STATION SINGLE LEVER CONTROLS

The 2090 Series is the only control of its type in the world and offers the ultimate in simplicity, performance and durability. On a two-station system both handles move together. For this reason only two control heads and four cables are required for a complete single engine two-station system.

With all other controls of this type the control must be put into neutral when going from one station to the next, the clutch re-engaged and the engine accelerated at the next station. These systems, requiring five components and seven cables, are constructed mainly from corrosive materials. They do not work as well as Kobelt Controls and are more expensive. For the short time that the 2090 Series Control System has been on the market it has proven to be a tremendous success.

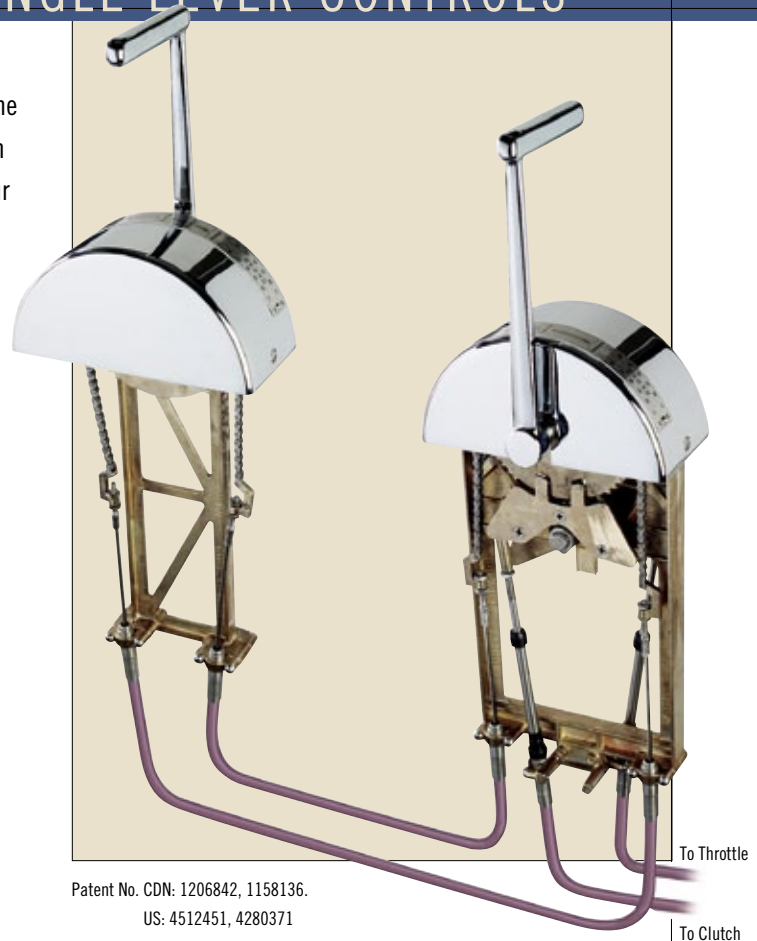

Patent No. CDN: 1206842, 1158136.
US: 4512451, 4280371



2091/2092/2093/2094 TWO STATION SINGLE LEVER CONTROLS

The 2091 and 2092 master control heads feature a pull-out handle for overriding throttle. All models are made entirely of die-cast silicon bronze and stainless steel hardware and are backed with our five year warranty. The maximum clutch stroke is 2 3/4" (70mm) and the maximum throttle stroke is 2 1/4" (57mm). Various connection points provide the correct travel for your engine and gear. The 2093 and 2094 remote controls are of the same rugged design. While the 2091 and 2093 are the same size, model 2094 is narrower than its master control, Model 2092.

Letter code designations:

Model 2091 (master) : H, K, L, M, U, Y, Z

Model 2093 (remote) : K, L, M, U, Y, Z

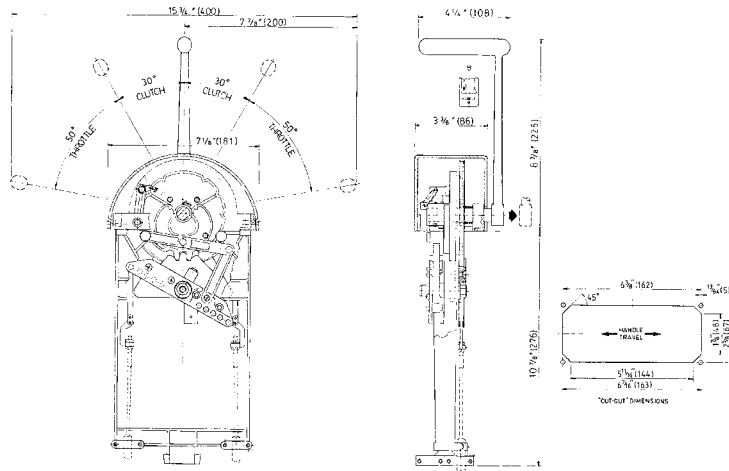

Letter code designations:

Model 2092 (master) : J, K, L, M, U, Y, Z

Model 2094 (remote) : K, L, M, Z

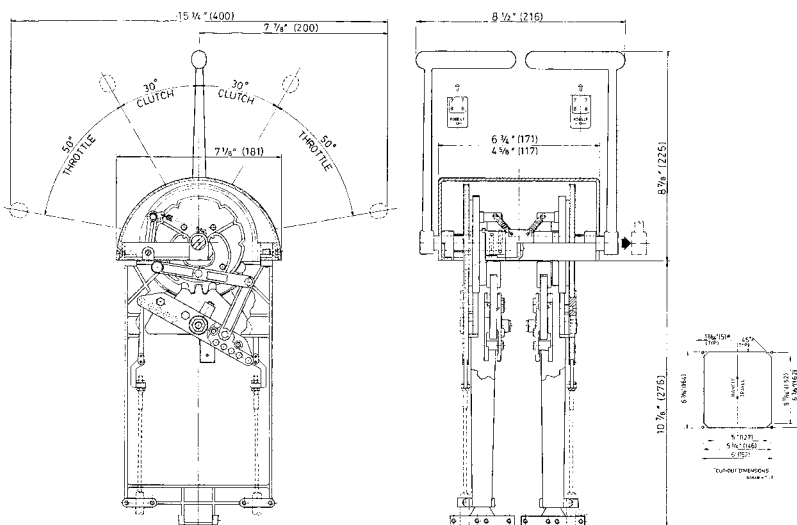

2091



2092

See installation instructions on Page 28.

2095/2096/2097/2098 TWO STATION SINGLE LEVER CONTROLS

The 2095 and 2096 are based on our models 2091 and 2092 with the addition of illuminated side scales. Model 2096 has a pull-out overriding throttle which isn't available on the 2095. The clutch and throttle stroke is the same as the non-illuminated models. Models 2097 and 2098 are illuminated remote control heads. It is possible to combine illuminated and non-illuminated models. The 2095 and 2097 are the same size while model 2098 is narrower than its master control 2096.

Letter code designations:

Model 2095 (master): **H, K, L, M**

Model 2097 (remote): **K, L, M**

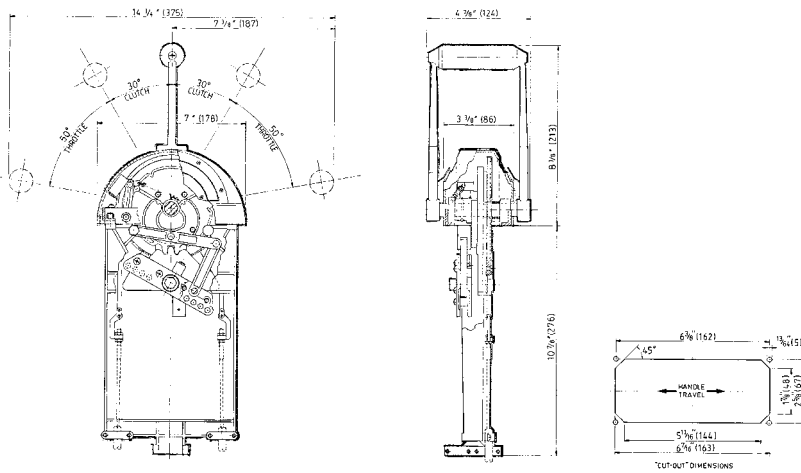

Letter code designations:

Model 2096 (master): **J, K, L, M**

Model 2098 (remote): **K, L, M**

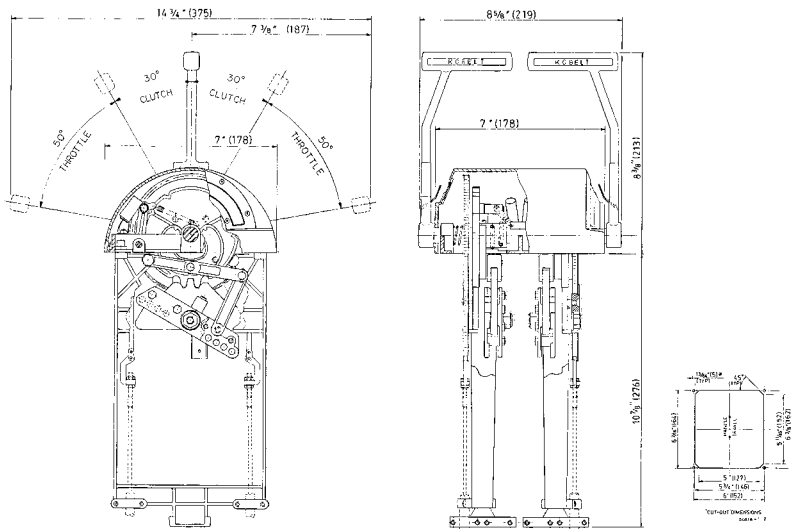

2095

2096

See installation instructions on Page 28.

ACCESSORIES

Kobelc Manufacturing provides a wide range of accessory items such as levers, adapter kits, rod ends, etc. as illustrated on this page. Our latest development is a universal adapter kit called "Catchbolt*" which replaces all specialty adapter kits now manufactured. Its extreme flexibility will allow you to install your cables on any engine and gear in "no time". Inventory costs are enormously reduced because of the flexibility.

Note: Levers must be pinned to shaft to avoid slippage.

*patent pending



XX stands for the model number

2123 UNIVERSAL CABLE TRANSFER UNIT

The Universal Cable Transfer Unit is a very useful device in Push-Pull Control systems where motion reversal is necessary or where the span of movement must be altered. The ability to connect cables (up to 4) at various connection points on the opposite side of the main lever provides all these functions. It is possible to increase the stroke from 3" to 4" cable or reduce the stroke from 3" to 2" cable. Construction is all bronze and stainless steel.

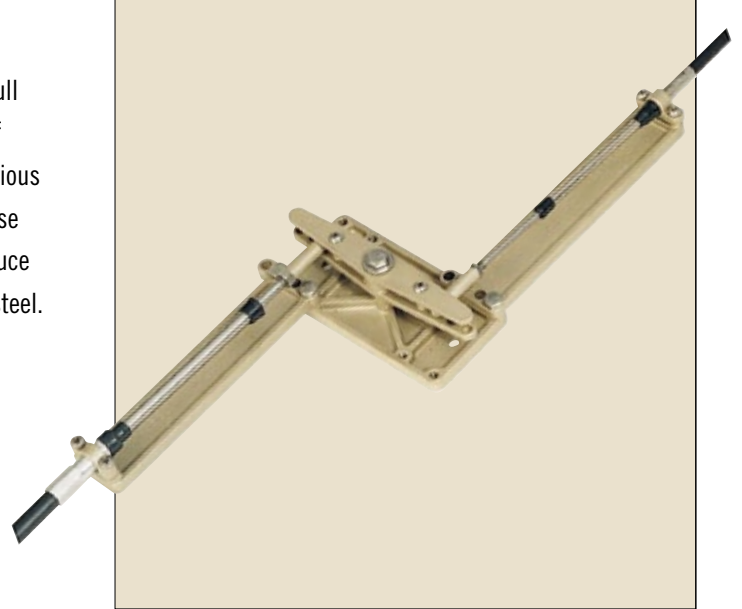
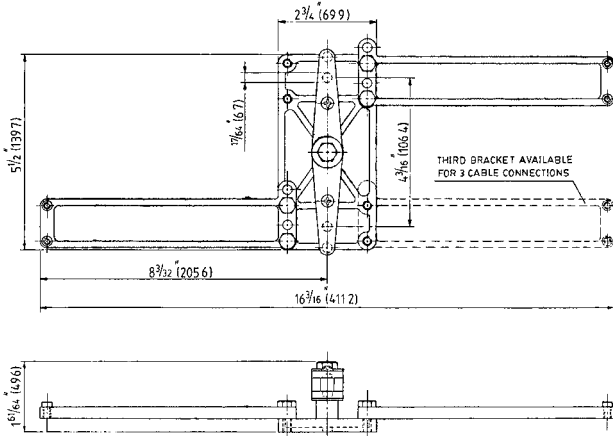

2124 COMPOUND UNIT

The Compound Unit was developed for two-station applications and for use on compound engine arrangements. On two-station applications, long cables sometimes require the use of 40 series cable from the wheelhouse to the engine room, but many in-board/out-board engines are designed for connection to a 30 series cable. The Compound Unit can be installed just below the wheelhouse floor. Both stations are connected to it with a 30 or 40 series cable which runs to the clutch throttle. On compound engine installations, the control cable runs into the Compound Unit and two cables lead away to the separate engine throttles.



Cable connection kits are available for any combination of cables.

Kits include:

Ordering No.	33 Series Cable	43 Series Cable
2124-0033	3	—
2124-0043	—	3
2124-0143	2	1
2124-0243	1	2

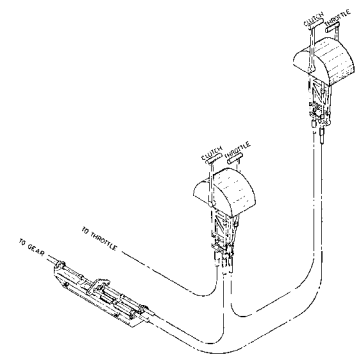
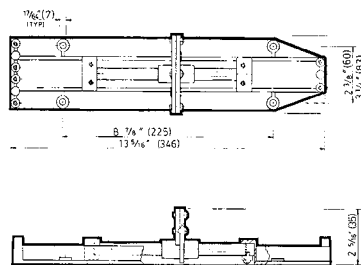

2128 UNIVERSAL ADAPTOR KIT

Catch-A-Bolt

This universal adaptor kit was developed in order to avoid stocking hundreds of different adaptor kits. Its title explains its function. Virtually any bolt, or preferably two bolts on the gear or engine, close to cable attaching point, can be used to install this universal adaptor kit. With its linkage and swivelling ends, cables can be run directly to the clamping bracket and allow easy cable installation; this avoids costly designing and fabrication. It can be used for parallel or series installations.



Clamp Kits for Model 2128

Cables Attached	Ordering No.
one-30 series	2128-0031
two-30 series	2128-0032
one-40 series	2128-0041
two-40 series	2128-0042

2170 ELECTRIC CLUTCH CONTROL

Kobel Manufacturing has developed an electric gearshift adaptor which can be connected to all Push-Pull controls (Single and Two Lever except Model 2010).

The purpose of this adaptor is to control electrically actuated clutch controls.

The electric gear shift adaptor is easily installed in the control head. On a two lever system, a second station can be connected with Push-Pull cables to the master station. Solenoid valves are provided by the gear box manufacturer to actuate the forward and reverse direction in the marine gear. The electric gear shift adaptor is ordered with the control head number followed by "-0910". eg. 2009-0910

Maximum voltage: 250v

Maximum current: 3A

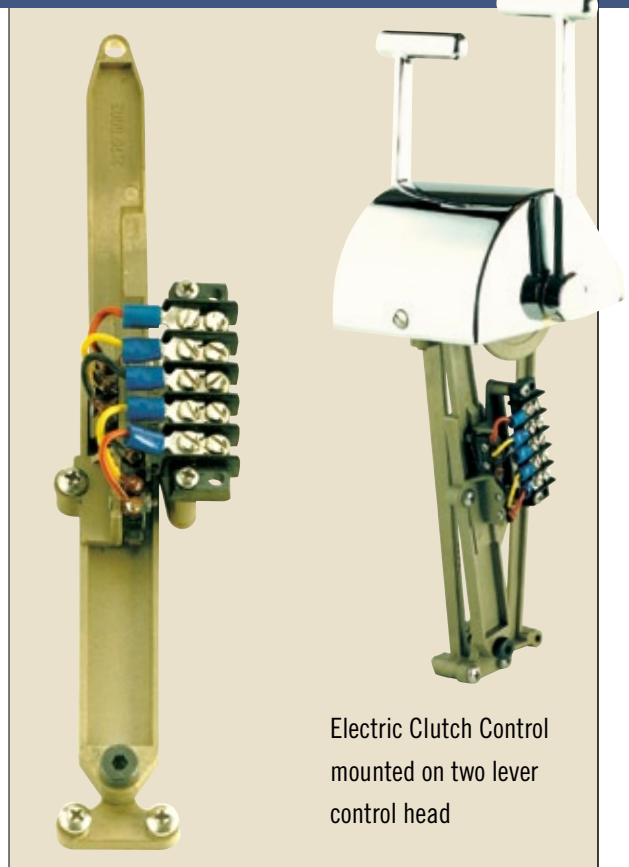

Electric Clutch Control mounted on two lever control head

HYDRAULIC SERVO CYLINDERS

Push-pull cables are not suitable for heavy workloads and become too stiff when operating heavy clutches and throttles. The wear and tear make it uneconomical. In order to solve these problems, Kobelt Manufacturing provides several servo cylinders which work off hydraulic pressure. They can be used to operate C.P. propeller lever mechanisms, hard-to-handle governor levers, jet drive buckets, etc. We can also provide controls for mechanically-actuated reverse reduction gearboxes, if a source of hydraulic pressure is made available (150-450 p.s.i.). In all of these systems the hydraulic cylinder provides infinite, fingertip control. It does not generate any unwanted stiffness in the push-pull system. As with all other Kobelt products you can expect years of trouble-free service.

Model 4602

(Model 4601 not shown)

The 4601 and 4602 are frequently used to control stiff throttles. The output signal is directly proportional to the input signal. Together with a 3015 pressure hold-back valve these units can also be used as hydraulic throttle delays using gear oil. This, however, lends itself only to gears having a differential pressure from the neutral position to the engaged position.

Model 4605

The 4605 cylinders consist of a double acting cylinder and a mechanically actuated spool-type directional control valve. These cylinders are commonly used for accurate positioning of jet buckets, controlling of C.P. propeller lever mechanisms and mechanical gear boxes.

Model 4607

The purpose of the 4607 is to provide a power assist for hard to move push-pull cable systems. Its maximum torque is 120 in-lbs. A terminal strip is provided for connecting either a 12V or 24V power supply. In order to install the wire, the cover for the terminal strip must be removed and the wire must be inserted through the connector provided and fed through to the terminal strip. The positive wire must be connected to the red wire and the negative to the white; correct polarity is imperative so as to not damage the unit. The terminal strip is located on the mechanical input side.

The cable coming from the control head must be connected to the input side. A pointer is provided on the shaft to indicate its position, since the bracket can be installed in six different ways. The lever must be removed to coincide with bracket and cable lead. The pointer must not be removed since it is the only indication for mid position. On the output side, the bracket can be installed in eight different ways. A 3" stroke cable can be installed on the input side and a 4" cable can be on the output side. By installing the input cable (3" stroke) on the second hole from the end of the input lever, and installing the output cable on the last hole on the actuator lever, it will increase the stroke to 3-3/4. On long cable runs it is more than likely that there will be a lot of lost motion in the incoming cable and by arranging the cable on lever the motion can be retained.

Order 4607-12 for 12 Volt, 4607-24 for 24 Volt.

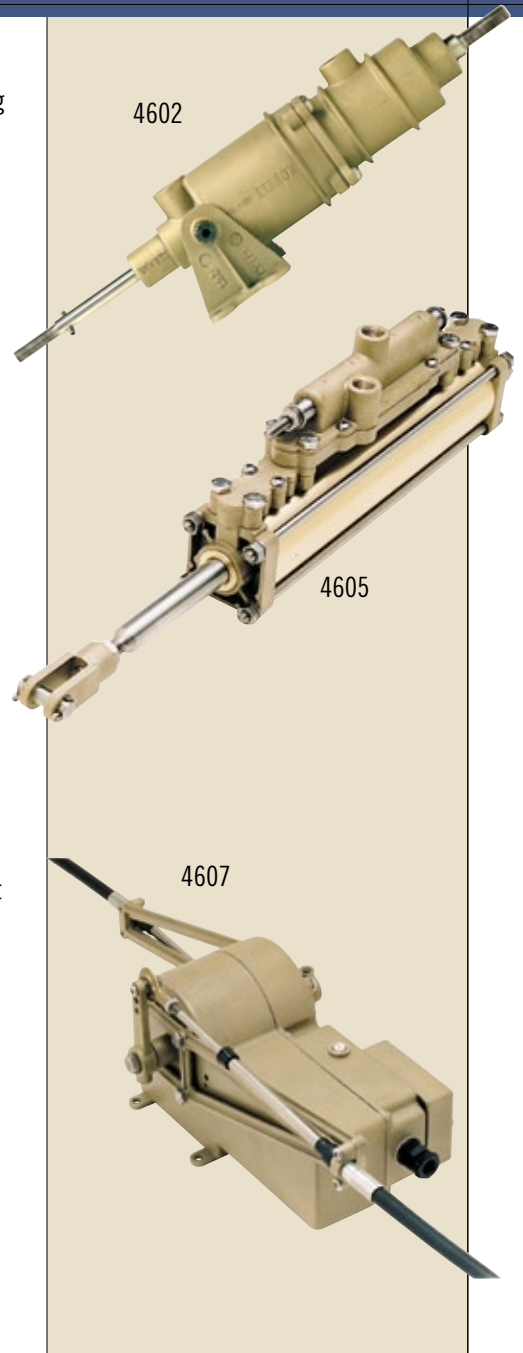

MODEL NO.	STROKE (MM)	BORE (MM)	MAX (PSI) PRESSURE
4601	1-3/4" (44)	2-1/2" (44)	250
4602	1-3/4" (44)	1-3/4"(44)	350
4605	4" (101.6)	1-3/4" (44.45)	500
	6" (152.4)	1-3/4" (44.45)	500
	8" (203.2)	1-3/4" (44.45)	500

2090 INSTALLATION INSTRUCTIONS

Installation instructions for 2090 Series

When installing the control heads, it is important that they are located on a clean, flat surface which is easily accessible. The cables leading from the main control head to the reverse reduction gear and the propulsion engine throttle should be installed and made functional first. It is important that the following points are carefully observed.

As illustrated in the drawing in Position A (showing the clutch actuating pivot plate in the gear engaged position and the control handle in the full speed position) the cable must pass slightly beyond the attaching point on the clutch actuating pivot plate in the pull mode. The cable must also go slightly beyond position B in the push mode with the control head in a full speed position.

In order to obtain equal excess travel in both positions on the cable, the adaptor kit cable-end must be adjusted accordingly. After the proper position is found, the cable-end is attached to the clutch actuating pivot plate. The locking nut must be secured. This will ensure that no mechanical binding takes place in the cable or the control head. It is also very important that the clutch control valve goes from neutral to both gear engaged positions without bottoming. A slight amount of end play is essential.

The throttle cable attached to the throttle actuating cam must also operate within the available stroke of the cable and the adaptor kit cable-end must be adjusted in such a manner to avoid bottoming of the control cable in either direction. In order to obtain full handle travel in the speed range it is important to select the appropriate connection point to the adaptor kit on the throttle cam.

After the master station is connected to the engine the cables can be connected from this station to the remote station. It is important that the cables are the right length. Too short a cable can result in tight bends which will increase friction. Too long a cable will also result in extra loops which again generate additional friction. Either of the above can make this control stiff and difficult to operate.

After the cable is attached with the clamps on the bottom of the supports of the control heads, the chain can be placed over the sprocket. When the control head is in the neutral position (handle in mid-position), the loose ends of the chain should be equally long on either side of the sprocket. The cable core is equipped with two nuts on either end. One of the nuts must be removed and the cable-end passed through the adaptor link. The nut can now be reinstalled.

It is also important to remember that the cable must be crossed between the control heads in order to get the handles to move in the same direction (the forward cable from the master station is attached on the aft side of the remote station and the forward cable of the remote station is attached to the aft side of the master station). The cables have enough thread at the end to allow balancing of the handles at both stations. This is best accomplished by placing the master station in the neutral position (handle straight up). The adjusting nuts at the end of the cable can now be tightened or loosened as required to balance the handles. Over-tightening of the cable core will result in excessive friction and will make the control system very stiff and difficult to operate. A deflection of $3/8$ "– $1/2$ " in the cable to either side between the sprocket and cable conduit clamp is essential. It is important that the two nuts and the cable-end are secured tightly against the adapting link. Two wrenches ($3/8$ "") must be used to accomplish this task. Under no circumstances must the chain be twisted when tightening these nuts.

Use only Felsted pull-pull cables to interconnect head and Felsted 40 series push-pull cables from control to gearbox/engine.

It is extremely important that all screws and nuts be securely tightened before the boat is placed into operation.

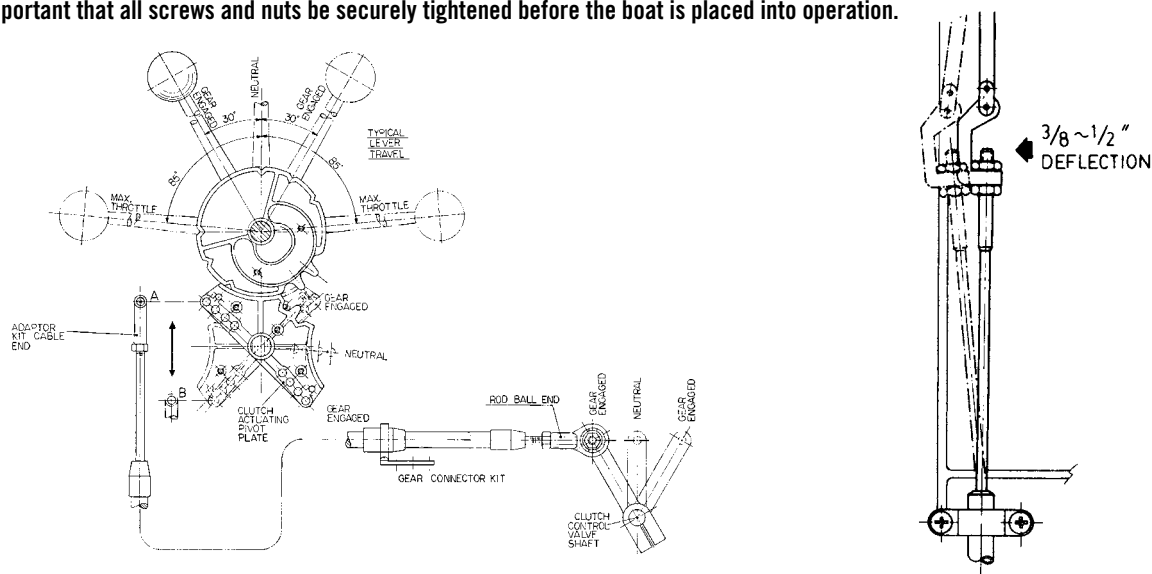

HOW TO INSTALL PUSH-PULL CABLES

Kobel Push-Pull control heads are designed with a removable dome for easy installation.

General Information

In order to provide a satisfactory push-pull control system, the following installation pointers must be considered:

- Install the control head on a flat and clean surface. An uneven surface tends to deform the control head frame and causes binding in the bearing sections.
- When attaching the cable to the control head or at the output end, it is important not to twist the inner core of the control cable. This will cause additional friction.
- It is not recommended to run cables in series since the Lost Motion becomes too excessive to ensure good control.
- The cable connectors at each end must be positioned in such a manner that the handles are synchronized and will take full travel in either direction without exceeding the available cable travel.
- It is very important that all cable attaching screws are firmly tightened. We recommend the use of "Loctite" or equal on the cable attaching screws on installations subject to severe vibrations.
- Use a small amount of grease on the cable connecting pins in the control head, and lubricate the bearing shaft and detent to improve the life and free movement of the control head.
- On two lever clutch and throttle control it is recommended that the stop screws in the control head be used to limit handle travel. This will prevent overloading of the control cable since only the required amount of travel can be used.

Dual Function, Single Lever Control Heads

Cable Installation

Initially, the cable shall be attached with the cable clamp to the support bracket. Screws must be securely tightened.

As illustrated in the drawing in Position A (showing the clutch actuating pivot plate in the gear engaged position and the control

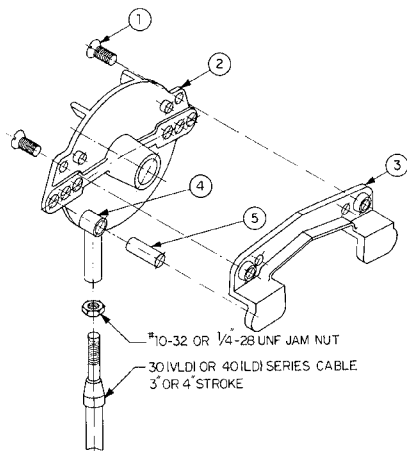

handle in the full speed position) the cable must pass slightly beyond the last attaching point on the clutch actuating plate in the pull mode. The cable must also go slightly beyond Position B in the push mode with the control head in a full speed position.

In order to obtain equal access travel in both positions on the cable the adaptor kit cable-end must be adjusted accordingly. After the proper position is found the cable-end is attached to the clutch actuating pivot plate. The locking nut must be secured. This will ensure that no mechanical binding takes place in the cable or the control head.

It is also very important that the clutch control valve goes from neutral to both gear engage positions without bottoming. A slight amount of end play is essential.

The throttle cable attached to the throttle actuating cam must also operate within the available stroke of the cable and, again, the adaptor kit cable end must be adjusted in such a manner to avoid bottoming of the control cable in either direction. In order to obtain full handle travel in the speed range it is important to select the appropriate connection point for the adaptor kit, on the throttle cam.

The clutch actuating pivot plate on the control head must complete its cycle in either direction without bottoming the cable in the pushing mode and without going beyond the maximum extended cable travel available in the pulling mode.

One Function Control Heads

Cable Installation

1. Loosen flat head screws (Item 1) to separate pin retainer (Item 3) from pivot plate (Item 2). Screws are provided with sufficient length allowing to insert the pin (Item 5) without total screw removal.
2. Install jam nut and cable connector (Item 4) onto end of cable.
3. Now slide pin into cable connector; place between pivot plate and pin retainer and tighten flat head screws (Item 1) securely.

Note: For installations subject to severe vibrations, use "Loctite" or equal when tightening the flat head screws (Item 1).

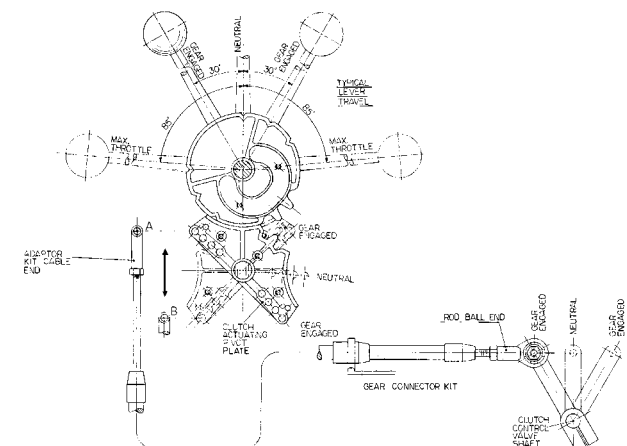

ONE STATION, SINGLE ENGINE, TWO LEVER PUSH-PULL CLUTCH AND THROTTLE CONTROL

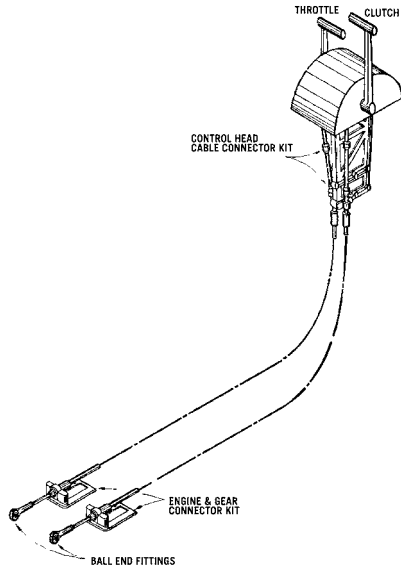

ONE STATION, TWIN ENGINE, TWO LEVER PUSH-PULL CLUTCH AND THROTTLE CONTROL

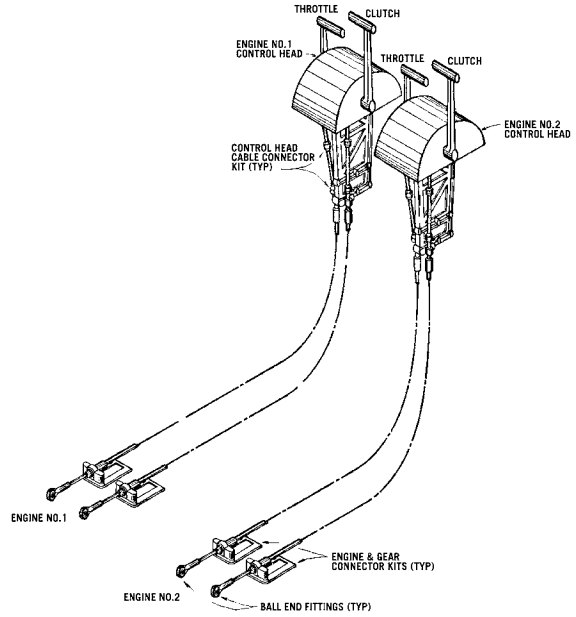

TWO STATION, SINGLE ENGINE, TWO LEVER PUSH-PULL CLUTCH AND THROTTLE CONTROL

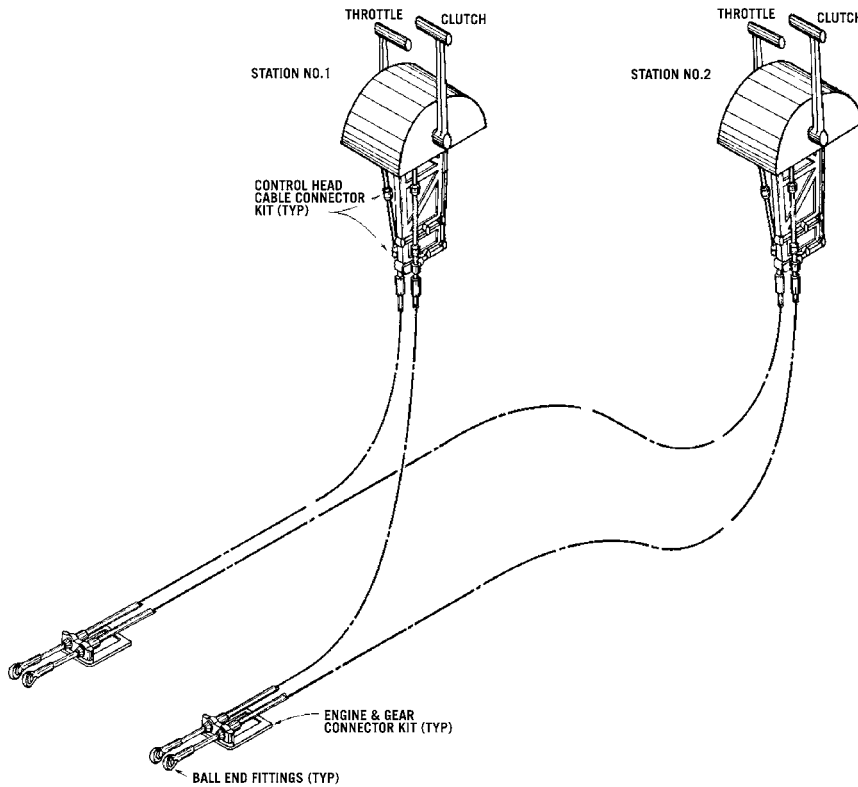

TWO STATION, TWIN ENGINE, TWO LEVER PUSH-PULL CLUTCH AND THROTTLE CONTROL (PARALLEL CONNECTED)

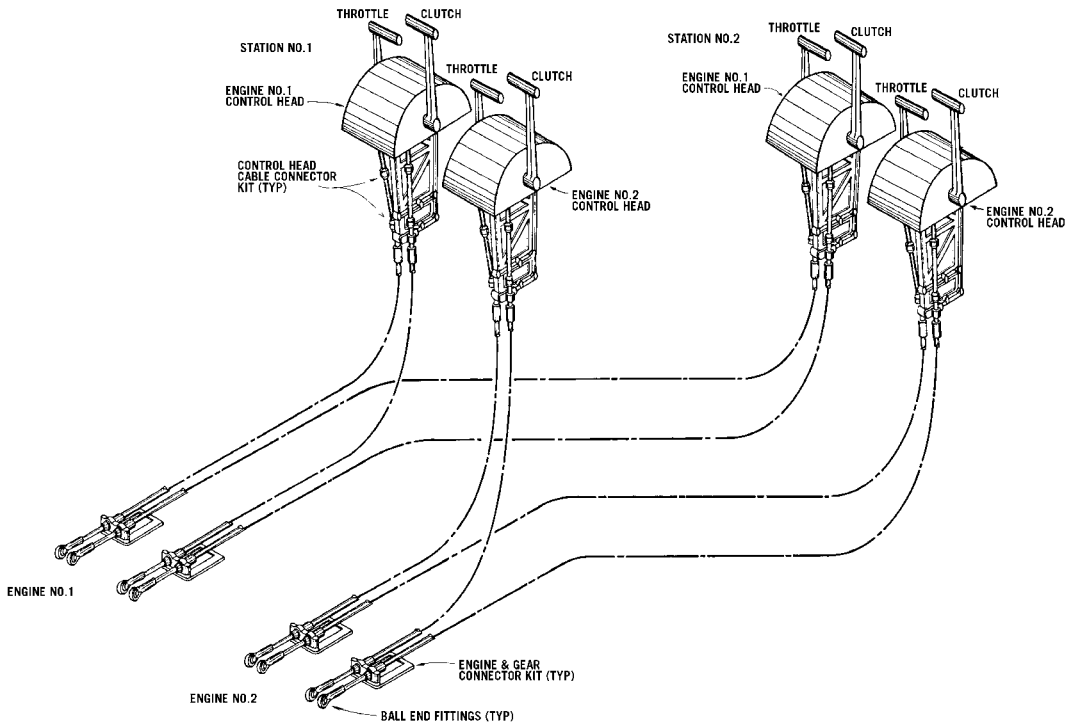

TWO STATION, SINGLE ENGINE, TWO LEVER PUSH-PULL CLUTCH AND THROTTLE CONTROL (IN SERIES CONNECTED)

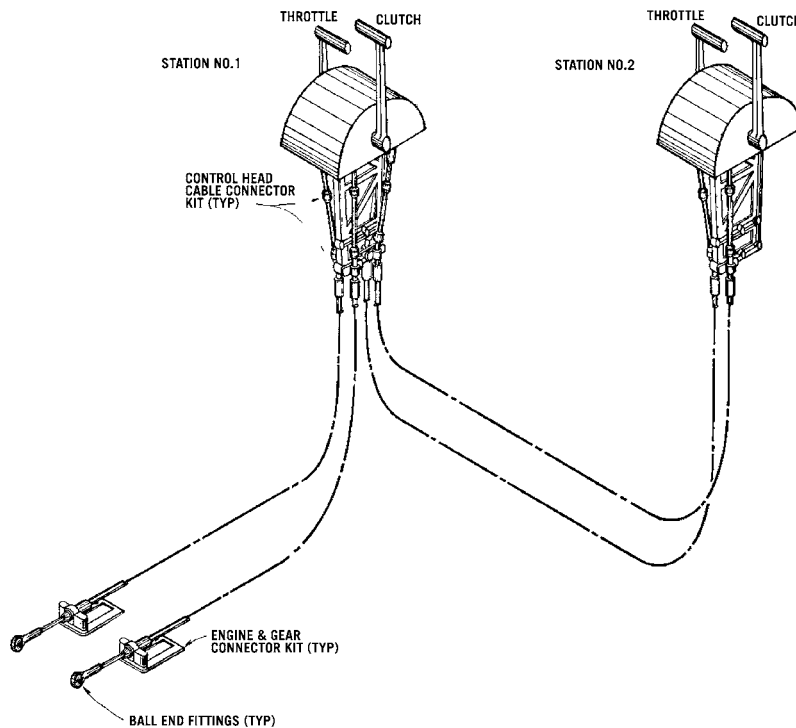

OUTBOARD STEERING

Ideally suited for outboard motors up to 300 HP, a basic system includes a helm pump, steering cylinder, fittings, hose or tubing and ISO 10 hydraulic oil.

The cylinders are available in standard bronze or epoxy-coated black finishes, and are typically differentiated by how they are mounted.

The 7030 cylinder attaches to the tilt tube. The cylinder rod passes through the tube and is connected to a link provided with the motor.

The 7032 cylinder is meant for front mounting to older model outboards. It can be used for twin outboards.

The 7033 cylinder (shown below) can be attached directly onto late model outboard motor brackets. The provided draglink connects the cylinder rod onto the motor tiller arm with stainless steel shoulder bolts. The swiveling arrangement allows the cylinder to be raised or lowered to suit the height of the tiller arm.

The 7029 tiebar is designed for multi outboard motor mechanical interconnection. Its purpose is to synchronize the movement of two or more outboard motors in order to obtain the same steering angle.

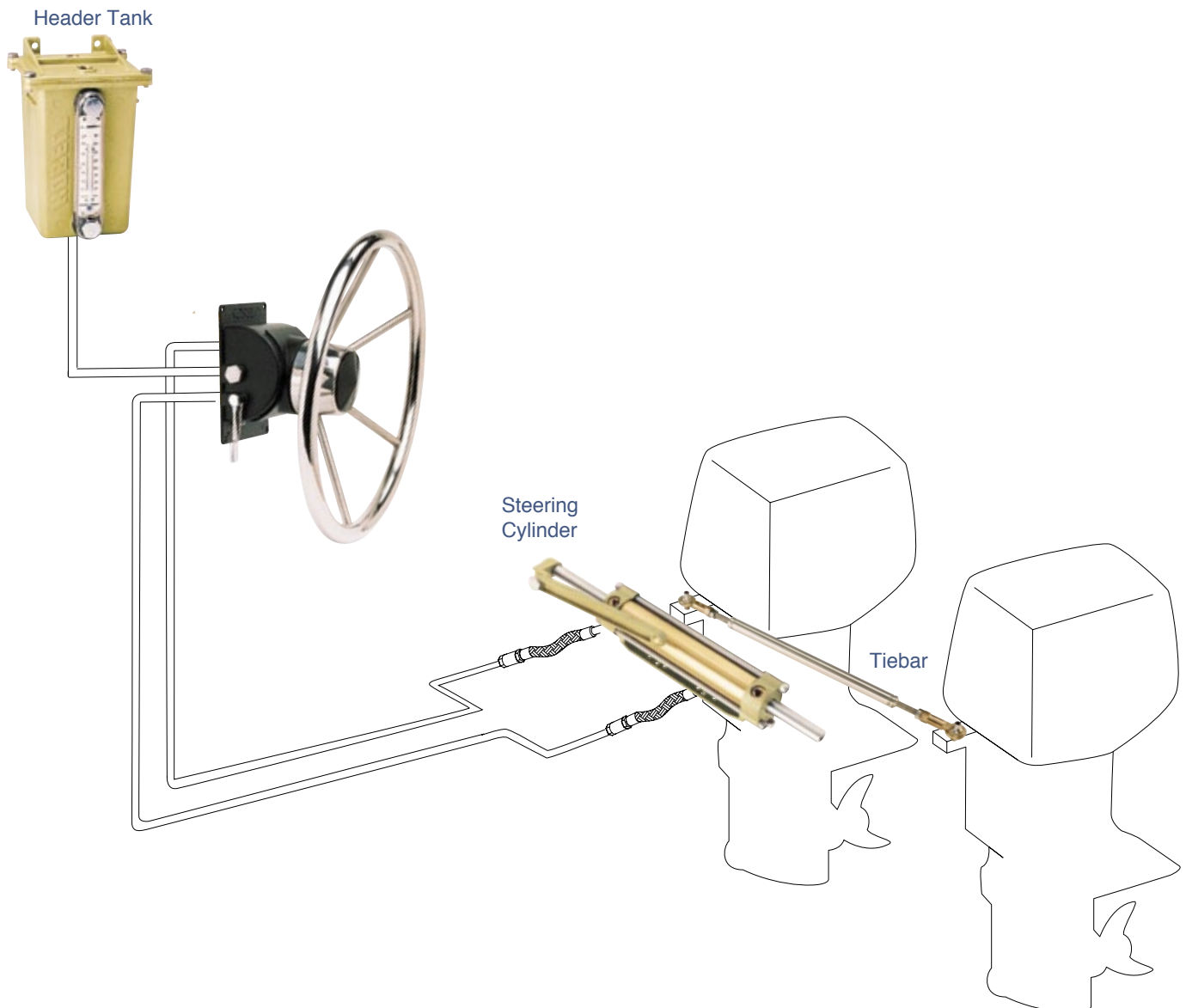

STEERING PRODUCTS FOR ALL APPLICATIONS

Kobelc manufactures steering cylinders from 1.25" I.D. up to 10" I.D. in strokes varying from 3" up to 6'. All piston rods are hard chromed and polished stainless steel.

Cylinders up to 3.5" bore have brass cylinder tubes; all other components are manufactured in die-cast bronze or stainless steel. Cylinders with a 4" bore and up have cylinder tubes and spherical bearings made from steel with all other components stainless and either die-cast or sand-cast bronze.

All low pressure operating cylinders are available in both balanced and unbalanced versions. The high pressure cylinders with 4" through 10" I.Ds. are only available in the unbalanced style. Unbalanced cylinders must be used in pairs in a steering system. If a single cylinder is used in a manual steering system, it is of utmost importance that the cylinder be of the balanced type.

"Balanced" means that the cylinder piston rod extends out of both ends of the cylinder tube, giving an equal volume of oil on both sides of the cylinder piston. This ensures a balanced torque on the steering components, as well as an equal number of wheel turns in both directions. A manual helm pump has a relatively small reservoir, and using an

unbalanced cylinder could cause the reservoir to overflow or the pump to run dry, either of which could disable the steering system.

"Unbalanced" cylinders have the piston rod extending out from only one side of the cylinder. Though occupying significantly less space in terms of "length", the result is added force on the side of the piston without the rod, making it the advantage of the unbalanced cylinder. When the two cylinders are plumbed, the hydraulic lines are crossed at the cylinders thus ensuring equal volume displacement in both directions.

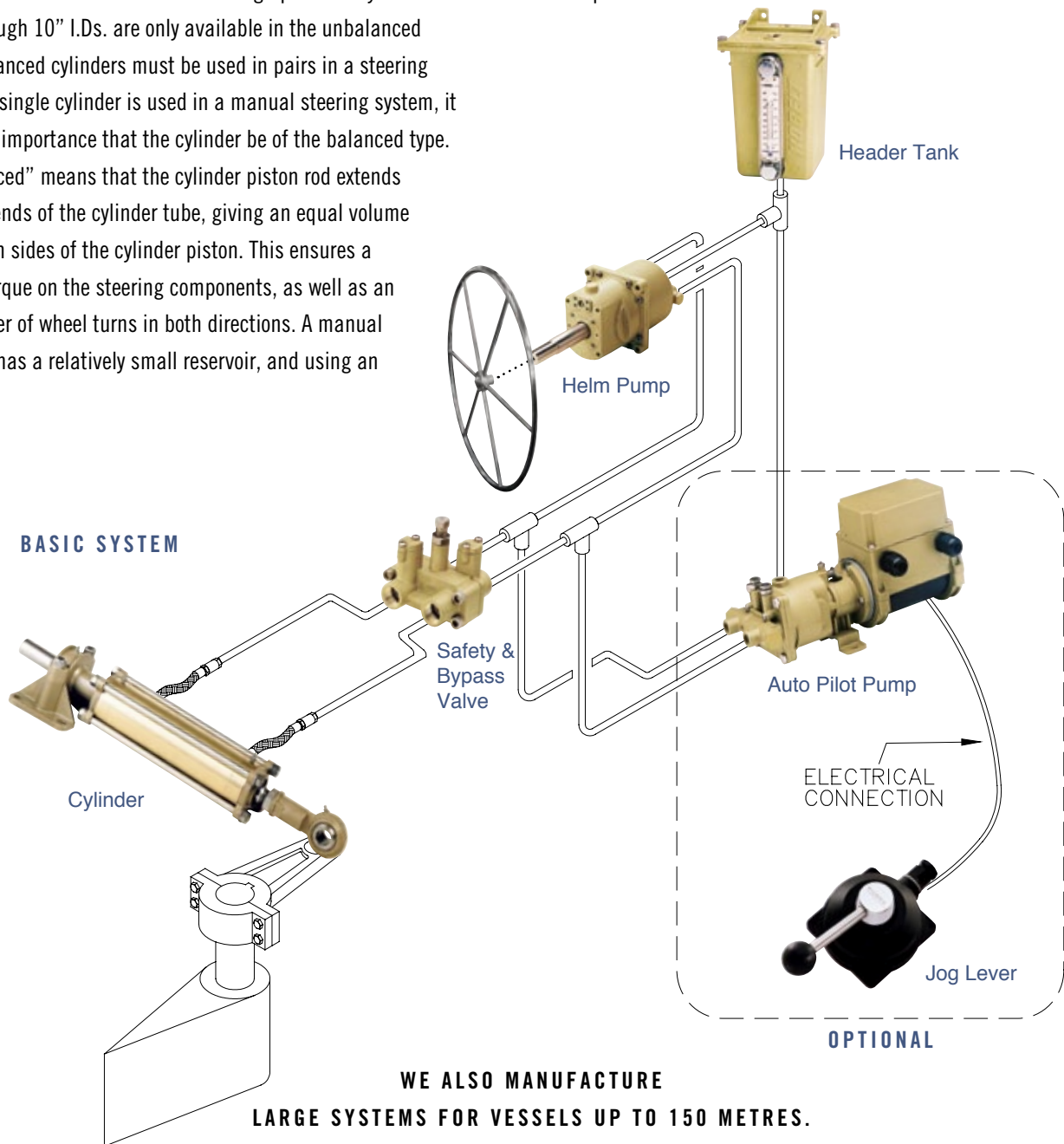

**WE ALSO MANUFACTURE
LARGE SYSTEMS FOR VESSELS UP TO 150 METRES.**

THE MIGHTY MARINER – MECHANICAL

The system is comprised of the basic 6505S control head in combination with the 6527-S electronic actuator, both in sturdy bronze and stainless steel.

The control head is completely watertight from the topside* and can be used in any location onboard. The 6527-S actuator is a stand-alone actuator† with manual override. The electronics are stored in the housing of the actuator itself, eliminating the need for a separate microprocessor unit. This simplified control system is perfectly suited for most boats, and has all the extra safety features found exclusively at Kobelt.

The Mighty Mariner is designed for Do-it-yourself installation. Communication is via a CAN Bus. This system offers up to 4 stations with station interface, station lock, overriding throttle and synchronization*.

* The bottom is not watertight and must be protected from the environment.

† Can only be used for clutch and throttle functions.

* Synchronizer kit is extra.

Choose The Mighty Mariner That's Right For Your Vessel

- Features:
- Self monitoring
 - System temperature monitoring
 - Clutch and throttle delay
 - Neutral safety
 - Station lock
 - Wire break monitoring
 - Potentiometer monitoring
 - Overriding throttle
 - Engine synchronization

Mighty Mariner Configurations:

- | | Part # |
|--------------------------------|-----------------|
| • Single Engine One Station | – Model 6500-S1 |
| • Single Engine Two Stations | – Model 6500-S2 |
| • Single Engine Three Stations | – Model 6500-S3 |
| • Single Engine Four Stations | – Model 6500-S4 |
| • Twin Engine One Station | – Model 6500-T1 |
| • Twin Engine Two Stations | – Model 6500-T2 |
| • Twin Engine Three Stations | – Model 6500-T3 |
| • Twin Engine Four Stations | – Model 6500-T4 |

Please specify colour of control heads at time of order.



**6505S
Control Head**

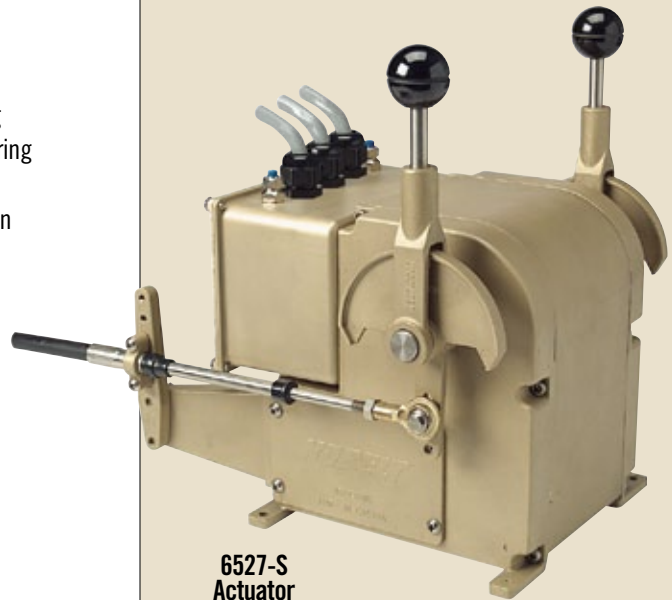

**6527-S
Actuator**

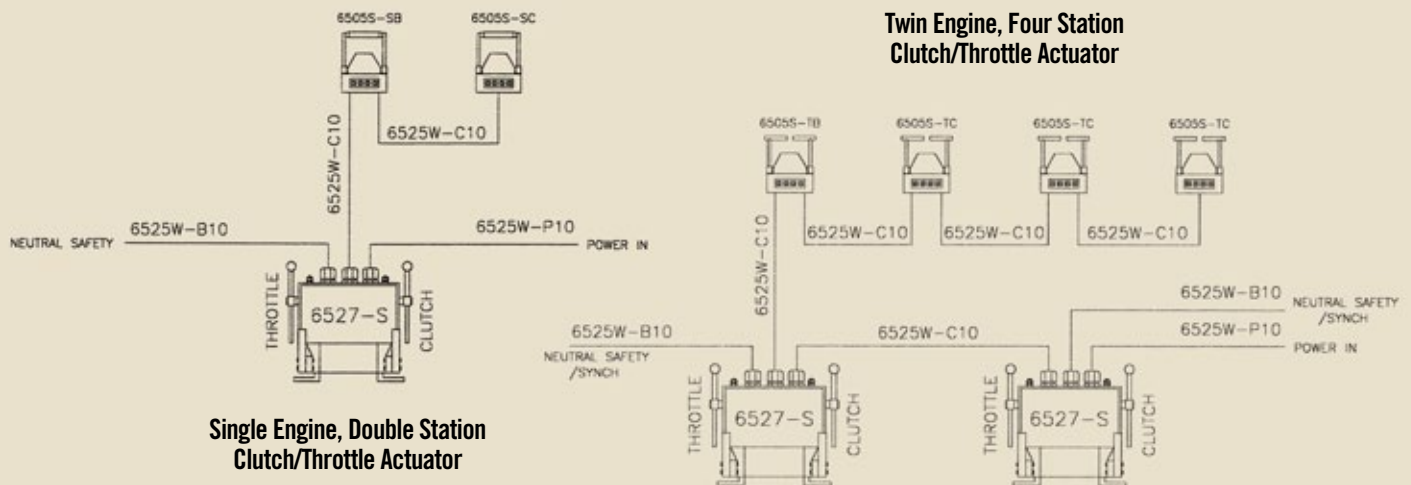

The Mighty Mariner system can be used with Electronic Clutch and Throttle interfaces.

The control heads are the same. However, a model 6503 processor is used to:

- Monitor all the input information from control heads and switch panels
- Communicate to the control heads and sonalerts
- Operate a clutch solenoid
- Operate the throttle signal for the engine

The 6505-2000 remote selector panel (shown on right) extends the range of products that can be used with the Mighty Mariner system. This remote panel has all the basic functions available on a 6505S control station and is suitable for inside or outside installations.

The control heads that can be used now include:

- 6506 Side-mount control
- 6555 Illuminated control
- 7176 Walk-about control
- and various other controls including joysticks

The drawing shown below is for a single engine, two station system. You can get systems for one or two engines, and from one to four stations.

There is more literature on our website: www.Kobel.com

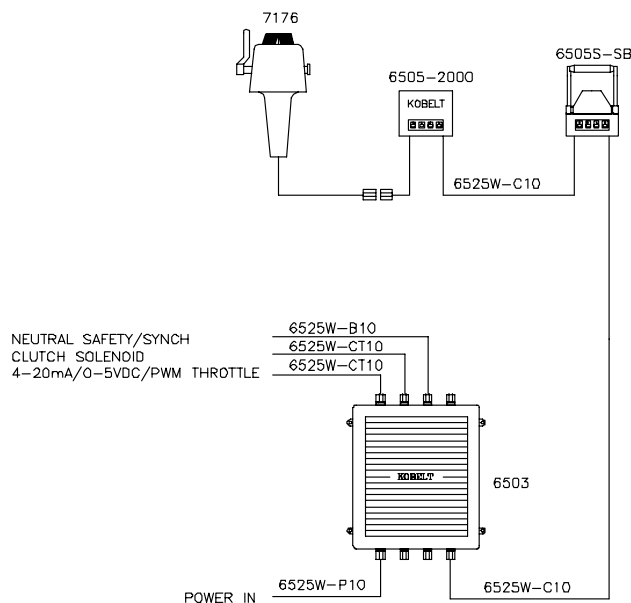

**6505S
Control Head**

Shown in single engine configuration



**6505-2000
Remote Panel**



**6503
Electronic Interface**

WE ALSO MAKE...

WIRE-OVER-PULLEY CONTROLS

Of all the various types of mechanical marine propulsion controls available, our experience has shown that the endless wire-over-pulley system gives accuracy and best response. The push-pull control, even with the finest components, will reach a point where it cannot meet certain requirements, i.e. long cable runs with many bends and several stations. At this point, if mechanical controls are required, we recommend the endless wire-over-pulley control system. Although this type of control requires a little more planning and installation time than the push-pull system, its operation is extremely sensitive and light.

The wire-over-pulley controls can be partially incorporated into push-pull systems as well as pneumatic systems. In fact, we manufacture all control components required for push-pull, wire-over-pulley and pneumatic systems.

Wire-over-pulley components are available for either two lever or single lever installations.



PNEUMATIC CONTROLS

We manufacture all components for any type of pneumatic control system. Best suited for vessels anywhere between 50 to 600 feet (15 to 180m), this control system features a limitless number of control stations. As additional stations do not affect the performance of the control system, the control heads move effortlessly, regardless of the distance or force required. The pneumatic control system, therefore, is one of the most flexible systems we offer. We can automate and synchronize as much, or as little, of your propulsion equipment as desired. We offer propulsion timing packages, to protect your propulsion equipment, with and without shaft brakes.



DISC SHAFT BRAKES

Kobelt has been designing and manufacturing disc brake systems for over 30 years. Most of our older brake calipers were manufactured in sand-cast bronze. Now most models are made entirely of die-cast silicon bronze with stainless steel hardware, more uniform in design and also more cost-effective. All of our calipers are available in either fluid or spring applied configurations. We also design brake discs to go with our die-cast calipers. All discs are ventilated and can be used for medium to heavy duty applications. Several types of brake linings are also available to conform with environmental guidelines.

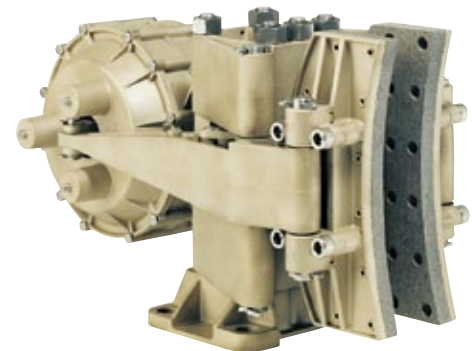

FOR MORE INFORMATION ON THESE, OR ANY OTHER KOBELT PRODUCT OR SYSTEM,
PLEASE CONTACT YOUR NEAREST KOBELT DEALER, OR VISIT US AT WWW.KOBELT.COM



Kobelt Manufacturing, Surrey, British Columbia, Canada

Ever since our humble beginnings in 1962, Kobelt Manufacturing Limited has been committed to manufacturing the finest marine controls in the world. We stress the importance of quality, precision, competitive pricing and prompt delivery. Our team of dedicated production staff is uncompromising in ensuring that we meet the needs of all our valued customers. Our growing reputation in world markets is proof of our commitment to highest possible standards. From our very first line of pneumatic controls we've believed in the simple things—rugged construction, quality materials and prompt delivery to our customers. Today, the technology has changed, but our commitment remains the same. From our innovations in electronic controls to our craftsmanship with bronze and stainless steel, our products span the oceans of the world to further our reputation as an international leader in maritime technology.



All Kobelt equipment comes with a 2-year conditional warranty that is the best in the industry. Strict quality control manufacturing and sturdy corrosion-resistant materials ensure trouble-free service above and beyond this generous warranty period.

KOBELT

8238 129th Street, Surrey
British Columbia, Canada V3W 0A6
Sales: 604.590.7313 Fax: 604.590.8313
sales@kobelt.com www.kobelt.com